

Wiring for Delta inverter VFD-B (mill & lathe)

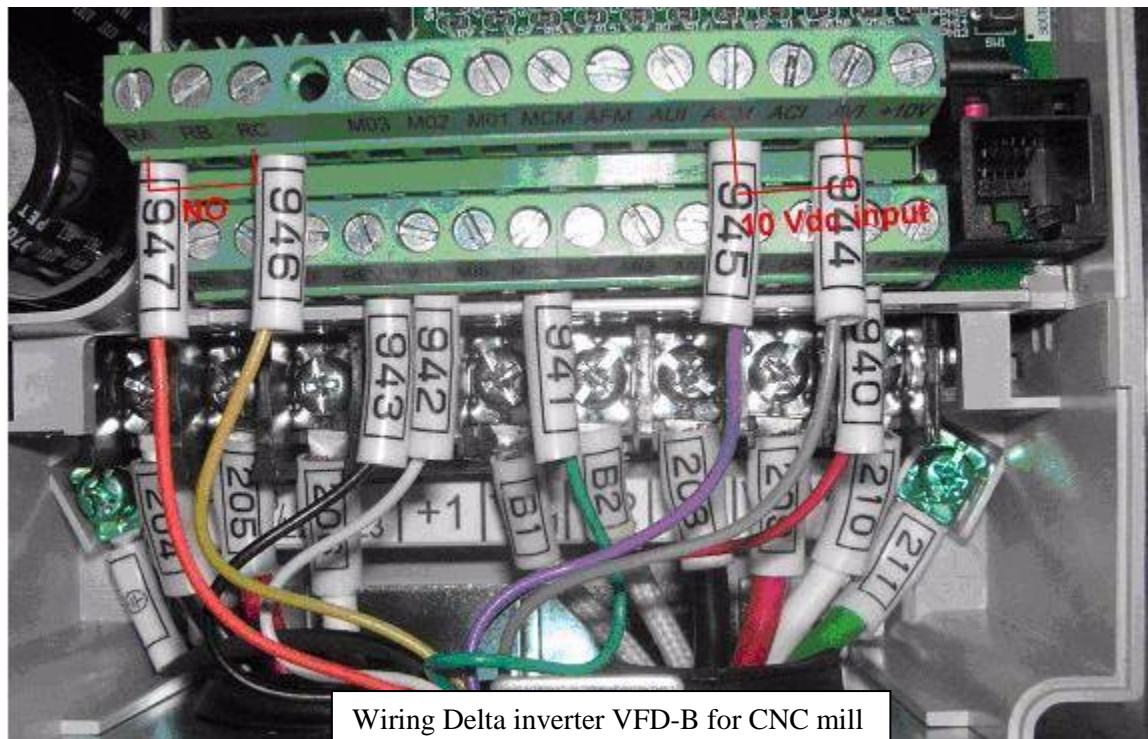

CNC Lathe: We add a wire #950 connecting from M01 (Zero speed) at inverter to input 24 at H20 - DC3IOB. Jumper RC and MCM (# 946 yellow)

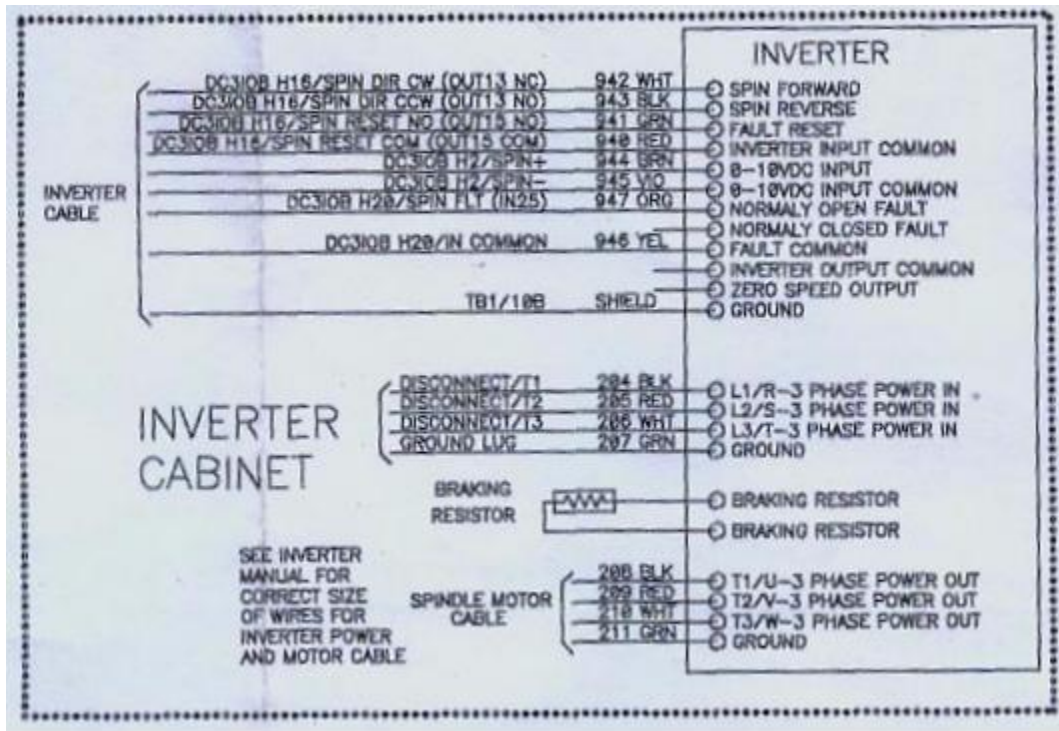
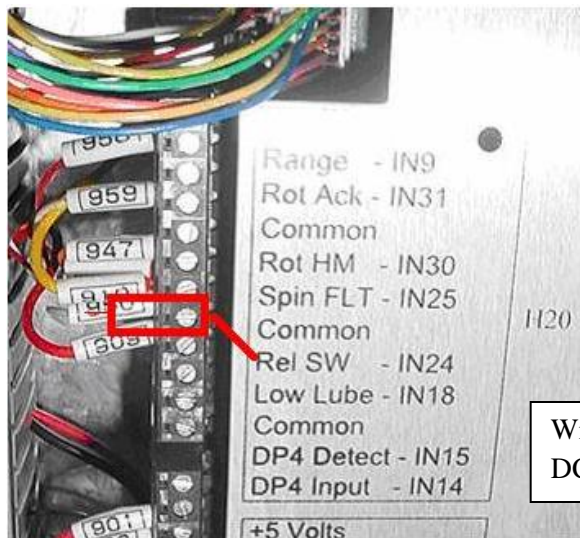

Wire #950 connects to input 24 at H20
 DC3IOB from M01 at inverter VFD-B