

NC LATHE

INSTRUCTION MANUAL AND PART LIST

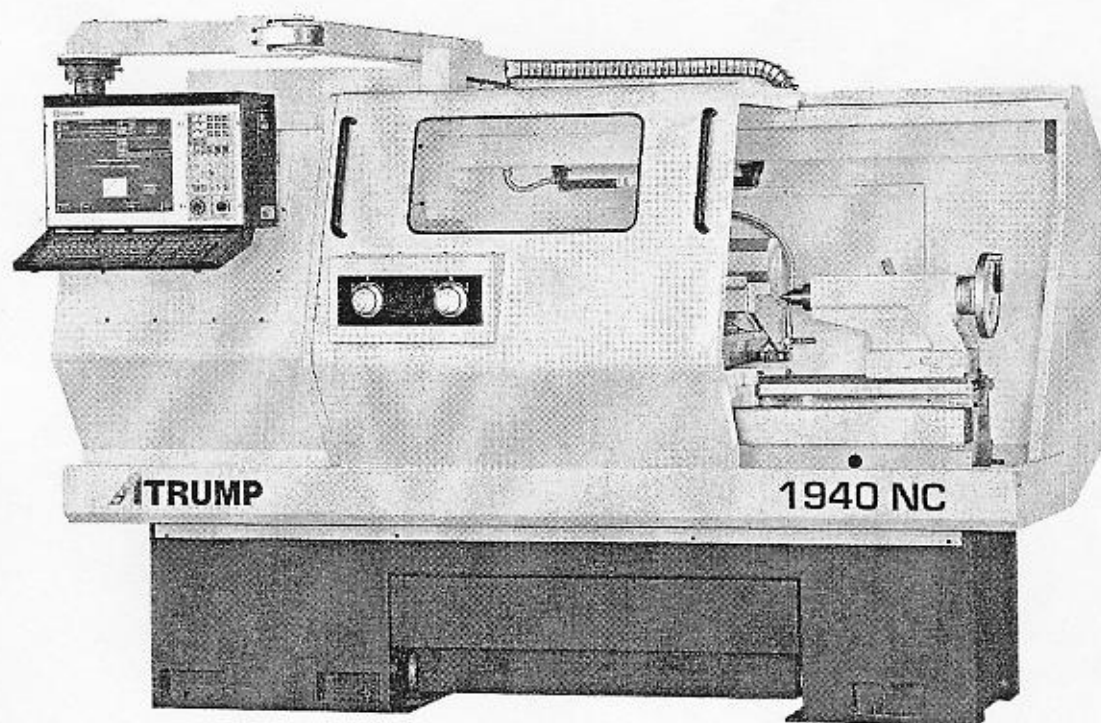

**MODEL : 1740NC 1760NC 1780NC
1940NC 1960NC 1980NC**

INDEX

| | |
|--|----|
| (1) SPECIFICATION AND ACCESSORIES | |
| GENERAL LAYOUT OF LATHE | 2 |
| MEASUREMENT | 3 |
| TRAVEL AND CAPACITY | 4 |
| BRIEF SPECIFICATION | 5 |
| FOUNDATION PLAN | 6 |
| | |
| (2) INSTALLATION | |
| CLEANING | 7 |
| LIFTING | 7 |
| INSTALLING | 8 |
| LUBRICATION | 9 |
| CHUCK AND CHUCK MOUNTING | 11 |
| | |
| (3) OPERATION | |
| SELECTION OF SPINDLE SPEED | 13 |
| TAIL STOCK | 14 |
| | |
| (4) MAINTENANCE | |
| SPINDLE BEARING ADJUSTMENT | 15 |
| SLIDE WAYS ATTENTION | 15 |
| LATHE ALIGNMENT | 16 |
| | |
| (5) PART LIST | |
| ASSEMBLY | 18 |

SPECIFICATION AND ACCESSORIES

GENERAL LAYOUT OF LATHE

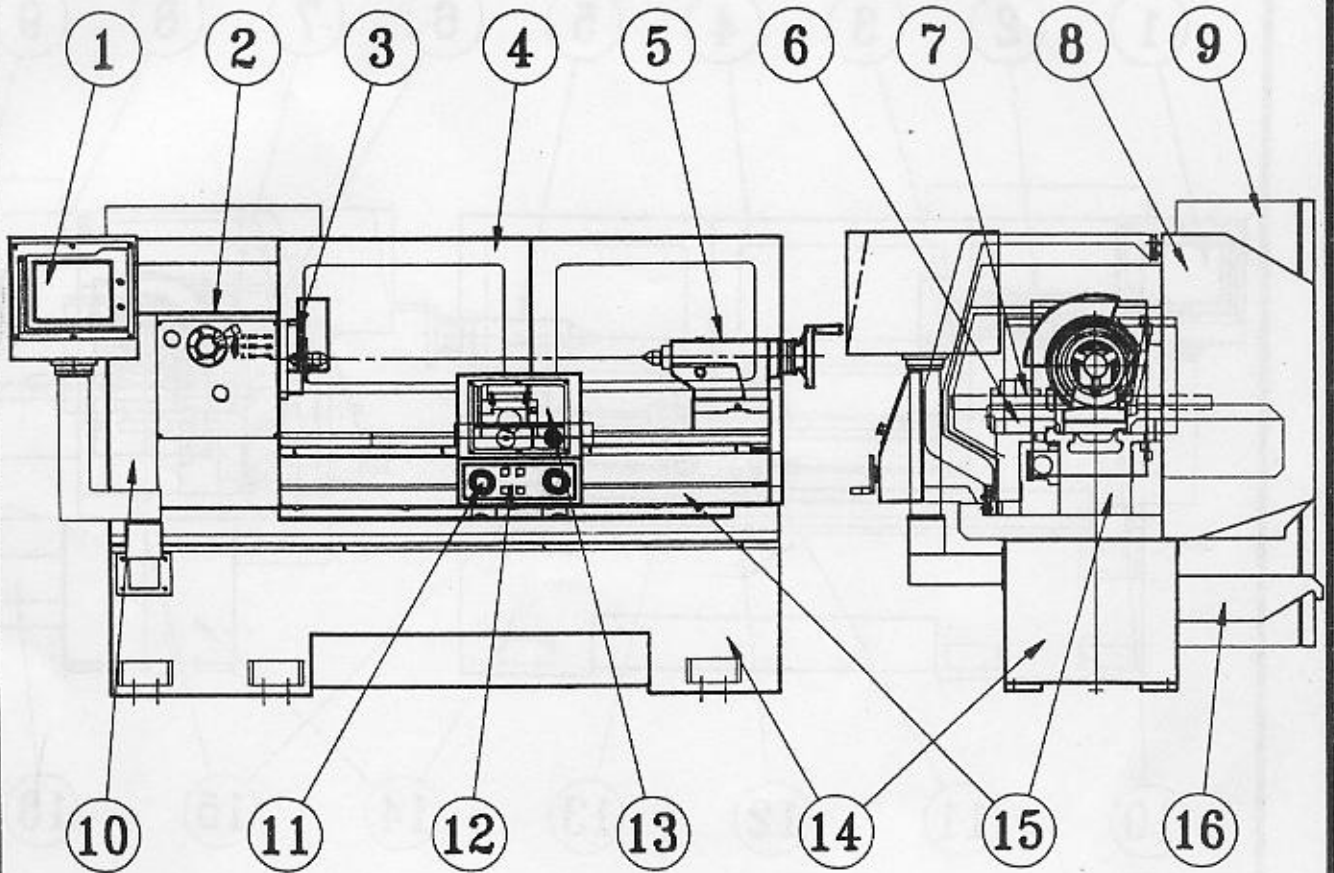

- | | |
|----------------------|--------------------------|
| 1. Monitor | 9. Electrical box |
| 2. Headstock | 10. Endcover |
| 3. Spindle | 11. Electronic handwheel |
| 4. Sliding door | 12. Control panel |
| 5. Tailstock | 13. Function key |
| 6. Saddle | 14. Stand |
| 7. Cross-slide | 15. Bedway |
| 8. Rear splash guard | 16. Chip pan |

SPECIFICATION AND ACCESSORIES

GENERAL LAYOUT OF LATHE

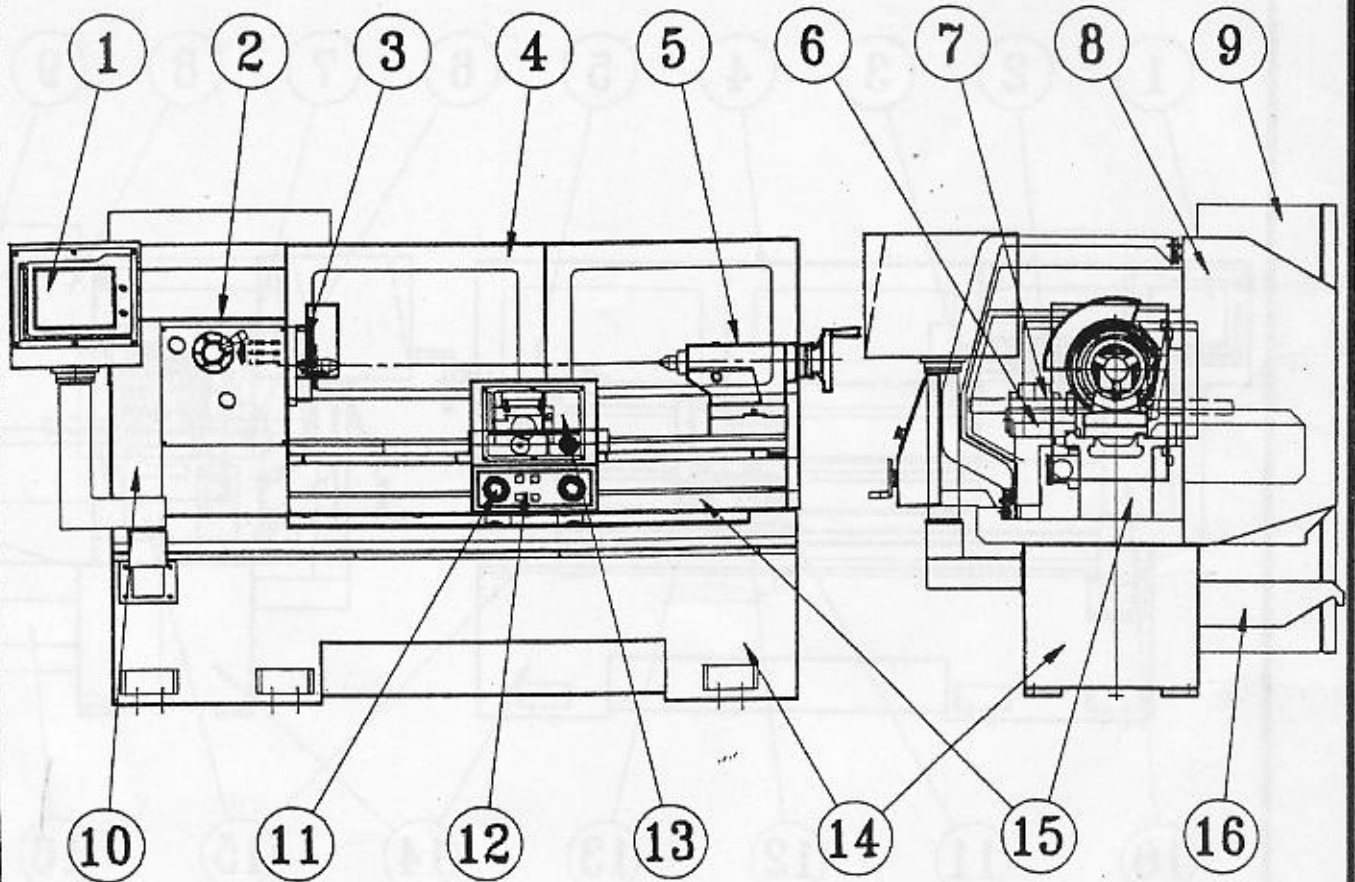

- | | |
|----------------------|--------------------------|
| 1. Monitor | 9. Electrical box |
| 2. Headstock | 10. Endcover |
| 3. Spindle | 11. Electronic handwheel |
| 4. Sliding door | 12. Control panel |
| 5. Tailstock | 13. Function key |
| 6. Saddle | 14. Stand |
| 7. Cross-slide | 15. Bedway |
| 8. Rear splash guard | 16. Chip pan |

SPECIFICATION AND ACCESSORIES

MEASUREMENT

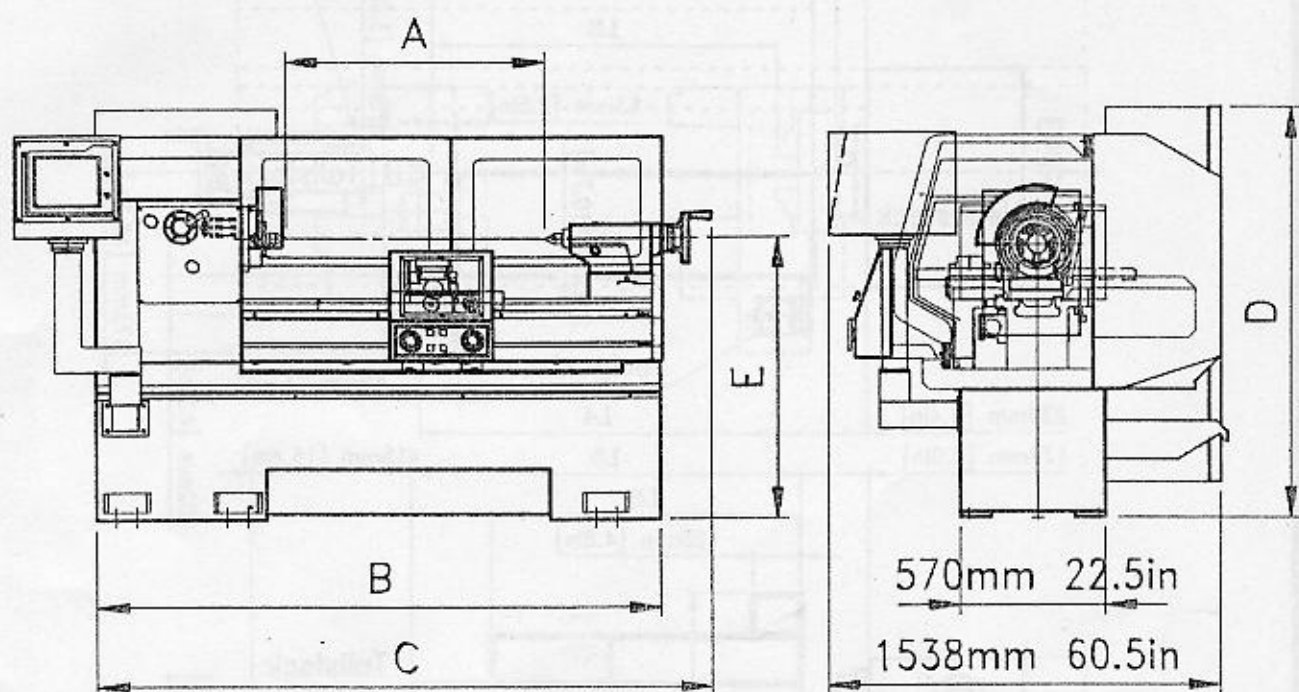

| MODEL | A | B | C | D | E |
|------------------|----------------|-----------------|-----------------|----------------|----------------|
| 440x1000 1740 | 1000mm 40in | 2190mm 86in | 2390mm 94in | 1610mm 63in | 1070mm 42in |
| 440x1500 1760 | 1500mm 60in | 2700mm 106in | 2900mm 114in | 1610mm 63in | 1070mm 42in |
| 440x2000 1780 | 2000mm 80in | 3210mm 126in | 3410mm 134in | 1610mm 63in | 1070mm 42in |
| 510x1000 2040 | 1000mm 40in | 2190mm 86in | 2390mm 94in | 1610mm 63in | 1105mm 44in |
| 510x1500 2060 | 1500mm 60in | 2700mm 106in | 2900mm 114in | 1610mm 63in | 1105mm 44in |
| 510x2000 2080 | 2000mm 80in | 3210mm 126in | 3410mm 134in | 1610mm 63in | 1105mm 44in |

SPECIFICATION AND ACCESSORIES

TRAVEL & CAPACITY

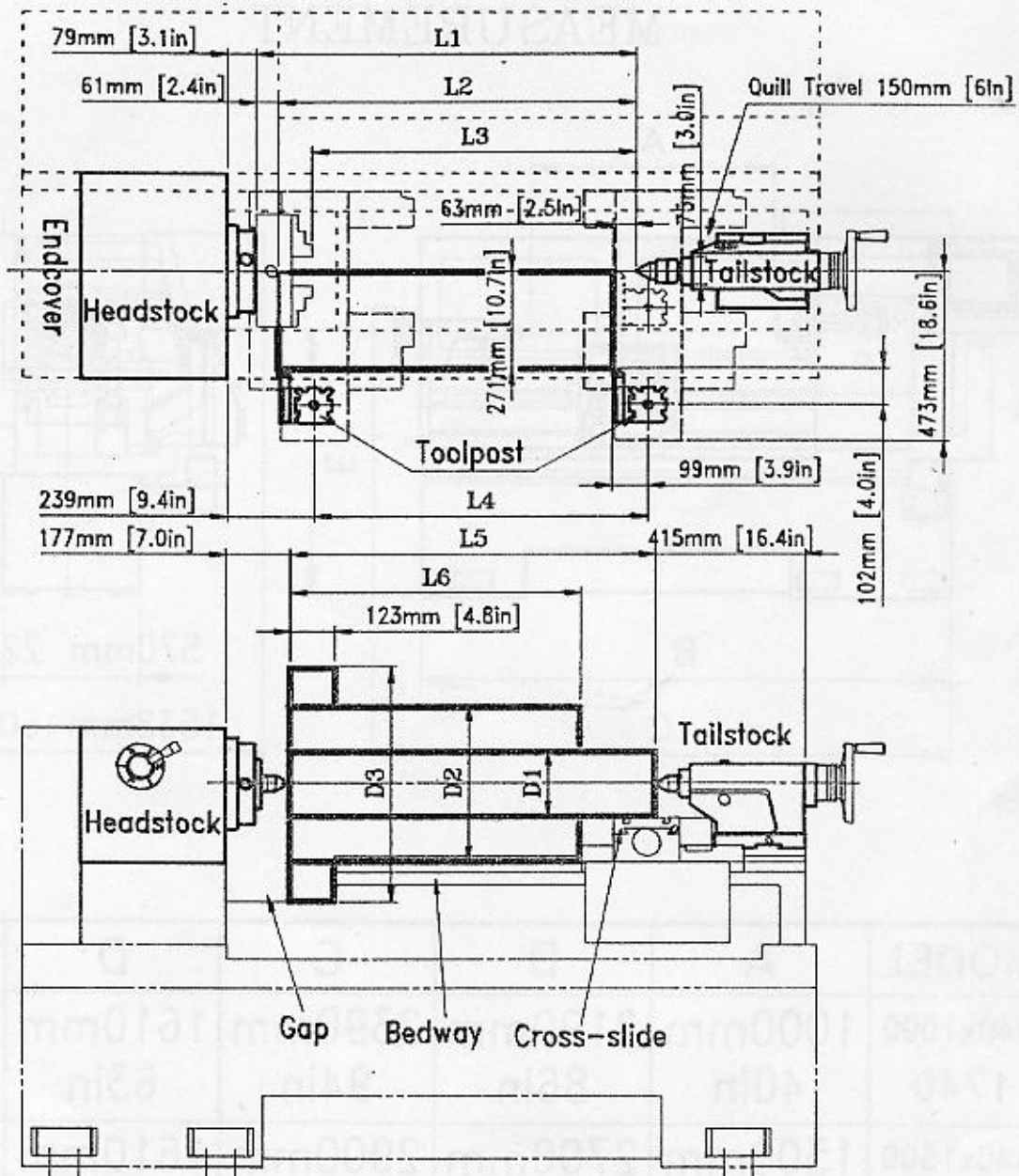

| MODEL | L1 | L2 | L3 | L4 | L5 | L6 | D1 | D2 | D3 |
|------------------|-------------------|-------------------|-------------------|-------------------|----------------|-------------------|------------------|------------------|------------------|
| 440x1000 1740 | 1045mm 41.13in | 984mm 38.72in | 893mm 35.14in | 920mm 36.22in | 1006mm 40in | 800mm 31.50in | 190mm 7.48in | 440mm 17.32in | 660mm 25.98in |
| 440x1500 1760 | 1555mm 61.20in | 1494mm 58.80in | 1403mm 55.22in | 1430mm 56.30in | 1516mm 60in | 1310mm 51.57in | 190mm 7.48in | 440mm 17.32in | 660mm 25.98in |
| 440x2000 1780 | 2065mm 81.28in | 2004mm 78.88in | 1913mm 75.30in | 1940mm 76.38in | 2026mm 80in | 1820mm 71.65in | 190mm 7.48in | 440mm 17.32in | 660mm 25.98in |
| 510x1000 2040 | 1045mm 41.13in | 984mm 38.72in | 893mm 35.14in | 920mm 36.22in | 1006mm 40in | 800mm 31.50in | 260mm 10.24in | 510mm 20.08in | 730mm 28.74in |
| 510x1500 2060 | 1555mm 61.20in | 1494mm 58.80in | 1403mm 55.22in | 1430mm 56.30in | 1516mm 60in | 1310mm 51.57in | 260mm 10.24in | 510mm 20.08in | 730mm 28.74in |
| 510x2000 2080 | 2065mm 81.28in | 2004mm 78.88in | 1913mm 75.30in | 1940mm 76.38in | 2026mm 80in | 1820mm 71.65in | 260mm 10.24in | 510mm 20.08in | 730mm 28.74in |

BRIEF SPECIFICATION

| | | | | | | |
|-----------------------------|-------------------------------|------------------|------------------|------------------|------------------|------------------|
| MODEL | 440x1000 1740 | 440x1500 1760 | 440x2000 1780 | 510x1000 2040 | 510x1500 2060 | 510x2000 2080 |
| NOMINAL SIZE | | | | | | |
| Swing over bed | 440mm 17-5/16in | | | 510mm 20in | | |
| Swing over cross slide | 190mm 7-1/2in | | | 260mm 10-1/4in | | |
| Height of center | 220mm 8-5/8in | | | 255mm 10in | | |
| Distance between centers | 1000mm40in | 1500mm60in | 2000mm80in | 1000mm40in | 1500mm60in | 2000mm80in |
| BED | | | | | | |
| Width of bedways | 330mm 13in | | | 330mm 13in | | |
| Total length of bed | 2000mm78in | 2510mm98in | 3020mm118in | 2000mm78in | 2510mm98in | 3020mm118in |
| Gap type | Swing over gap | 660mm 26in | | | 730mm 28-3/4in | |
| | Length of gap | 300mm 11-3/4in | | | 300mm 11-3/4in | |
| | Width in front of face plate | 190mm 7-1/2in | | | 175mm 6-3/4in | |
| SPINDLE | | | | | | |
| Spindle nose mounting | D1-8 CAMLOCK | | | | | |
| Spindle bore | 86mm 3-3/8in | | | | | |
| Taper of spindle bore | M.T.#7 (Sleeve M.T.#5) | | | | | |
| Number of spindle speeds | HIGH - MIDDLE - LOW | | | | | |
| Range of spindle speeds | 2000~240 - 380~45 - 84~10 RPM | | | | | |
| TOOL SLIDE | | | | | | |
| Total travel of cross slide | 280mm 11in | | | | | |
| Max size cutting tool | 25mm 1in | | | | | |
| TAIL STOCK | | | | | | |
| Total travel of barrel | 160mm 6-5/16in | | | | | |
| Taper in barrel | M.T.#5 | | | | | |
| Diameter of barrel | 75mm 3in | | | | | |
| MOTOR | | | | | | |
| Main spindle motor | 10 HP. 7.4kw | | | 10 HP. 7.4kw | | |

We reserve the right to modify and improve our products.

SPECIFICATION AND ACCESSORIES

FOUNDATION PLAN

- — M20x2.5 BOLT
- — 22mm (7/8in) HOLE

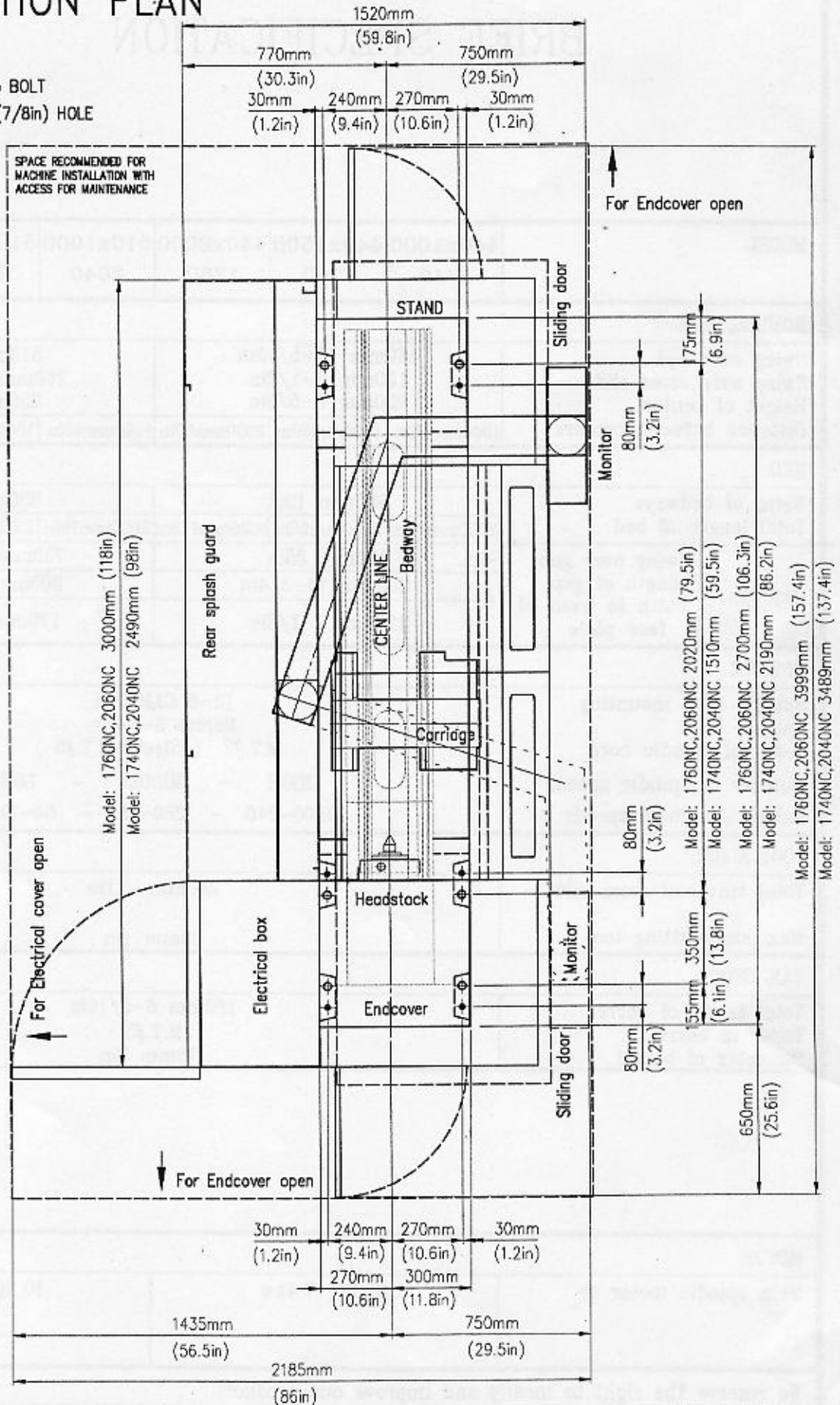

INSTALLATION

CLEANING

Before operation any controls, remove the anticorrosion coating from all slideways, and the endgear train, using white spirit or Kerosene.

DO NOT USE CELLULOSE SOLVENTS FOR CLEANING AS THEY WILL DAMAGE THE PAINT FINISH.

Oil all bright machined surfaces immediately after cleaning using machine oil or slideway lubricant, use heavy oil or grease on the endgear.

LIFTING

Move and lift the machine by using two 35mm(1-3/8") Diameter and 650mm(25") Long iron bar. Go through the hole of Bed and lift unpacking machine with a wire rope, which have enough capacity against gross weight of this machine.

Raising and lowering the machine should be careful. Do not touch the leadscrew, feedroad spindle or other handwheel.

Be careful not to bump the machinery against the floor.

In order to have the machinery properly balanced before hoisting, it is advisable to move Tailstock and Carriage to the extreme right-hand position; clamp both assemblies firmly in place so they will not accidentally slid to left when lifting.

IMPORTANT: DO NOT USE SLINGS AROUND OUTSIDE OF BED AS LEADSCREW AND FEEDSHAFT MAY BE BENT.

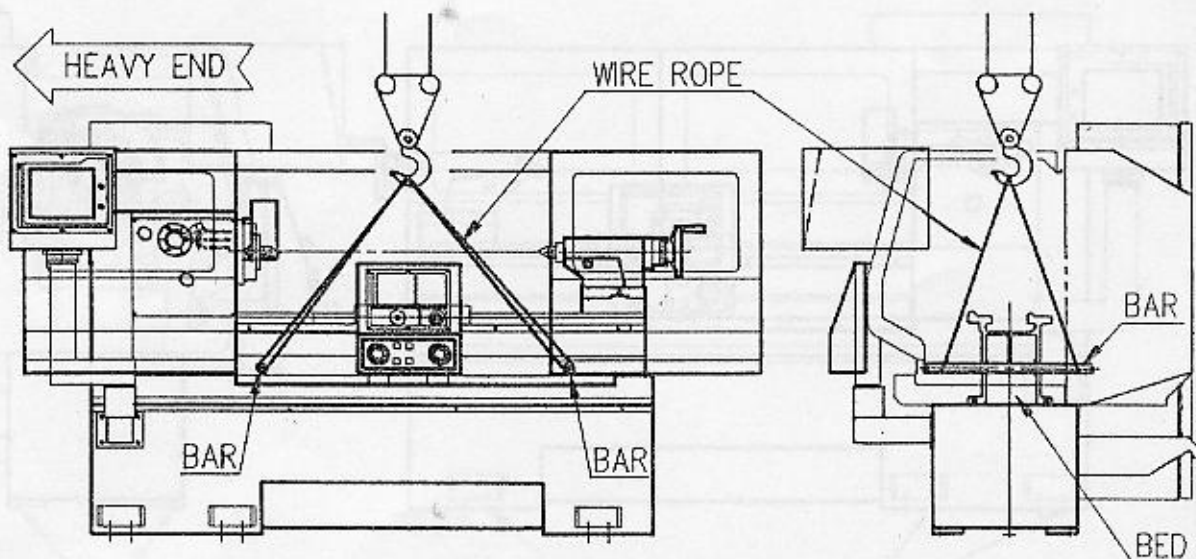

INSTALLATION

INSTALLING

Located the machine on a solid foundation, allowing sufficient area all round for easy working and maintenance (see Foundation plan). The lathe may be used free-standing or bolted to the foundation.

Free-standing: Position lathe on foundation and adjust each of the six mounting feet to take equal share of the load. Then using an engineers precision level on the Bedways adjust the feet to level up machine. Periodically check bed level to ensure continued lathe accuracy.

Fixed installation: Position lathe over six bolts (20 mm. diam.) set into the foundation to correspond with holes in the mounting feet. Accurately level the machine, then tighten hold-down bolts.

Re-check bed level

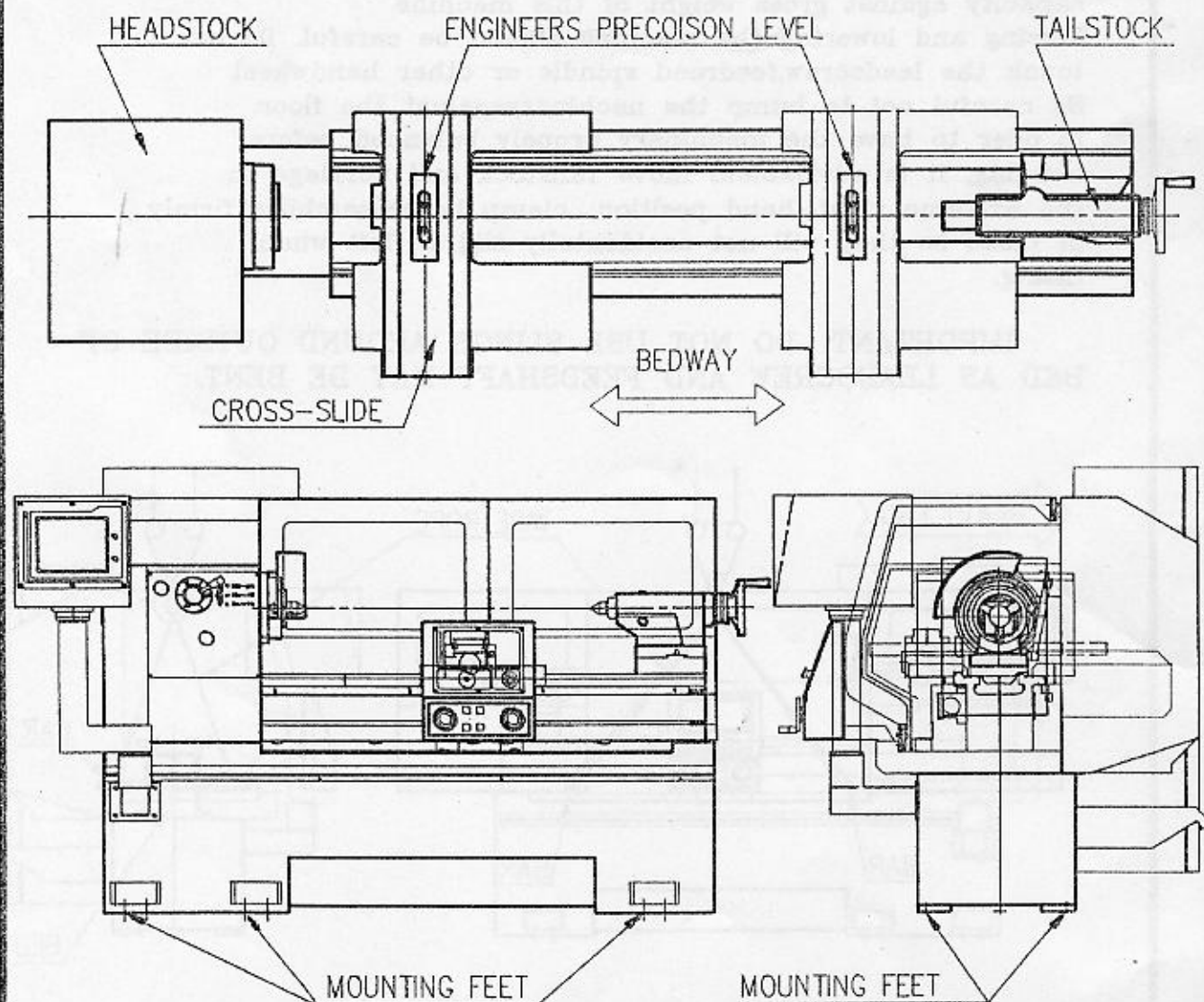

INSTALLATION

LUBRICATION

It is most important to lubricate lathe before operating!

The operator should be responsible for the proper lubrication of the lathe. The grade and quality of lubrication are given in the following OIL LUBRICATION CHART. The instructions on this chart are essential to the proper oiling of the internal of the lathe. Oil levels should be strictly observed, for it is of primary importance for proper operation and long life that the oil bath for the headstock which always be completely filled.

Gear pump equipped in the Headstock can be run to pour lubricated oil into every place of bearings through pipe while spindle rotating. The oilsight on the middle-lower side of headstock is oil gauge. Oil levels should be strictly observed, for it is of primary importance for proper operation and long life that the oil bath for the headstock should be always filled completely. The oilsight on the left-upper side of headstock can show if gear pump run normally. If the oilsight on the left-upper side of headstock shows without oil while spindle rotating, it means that lubricated system broke down and ought to be inspected and repaired for avoiding the bearings in headstock damaged.

Automatic lubrication pump, equipped at the back of the rear side of STAND, have been installed oil pipes to link with carriage, Cross Slide and the ball-screw nut of Z axis. This pump can provide lubricated oil periodically to pour into above three places for keeping fully lubricated function.

Directions for the oil lubrication pump

*Note the oil quantity will reduce gradually under normal application.

*Note whether the motor is running or not ?

- 1.Fill clean lubricant into the oil tank up to the top red line.
- 2.The oil tank preserves clean lubricant.
- 3.In case impurity remains in the oil tank so as to fail the oil feeding, please cleanse the oil absorbing net immediately.
- 4.First use the oil feeding button to fill up the empty pipes for normal application.
- 5.The adjustment of discharge is to release the fixing bolt and adjust it at desired figure displayed on the scale plate, so the figure is to show the discharge C cc/cy.
- 6.Oil surface below the red line. it is necessary to refill oil.

INSTALLATION

OIL LUBRICATION CHART

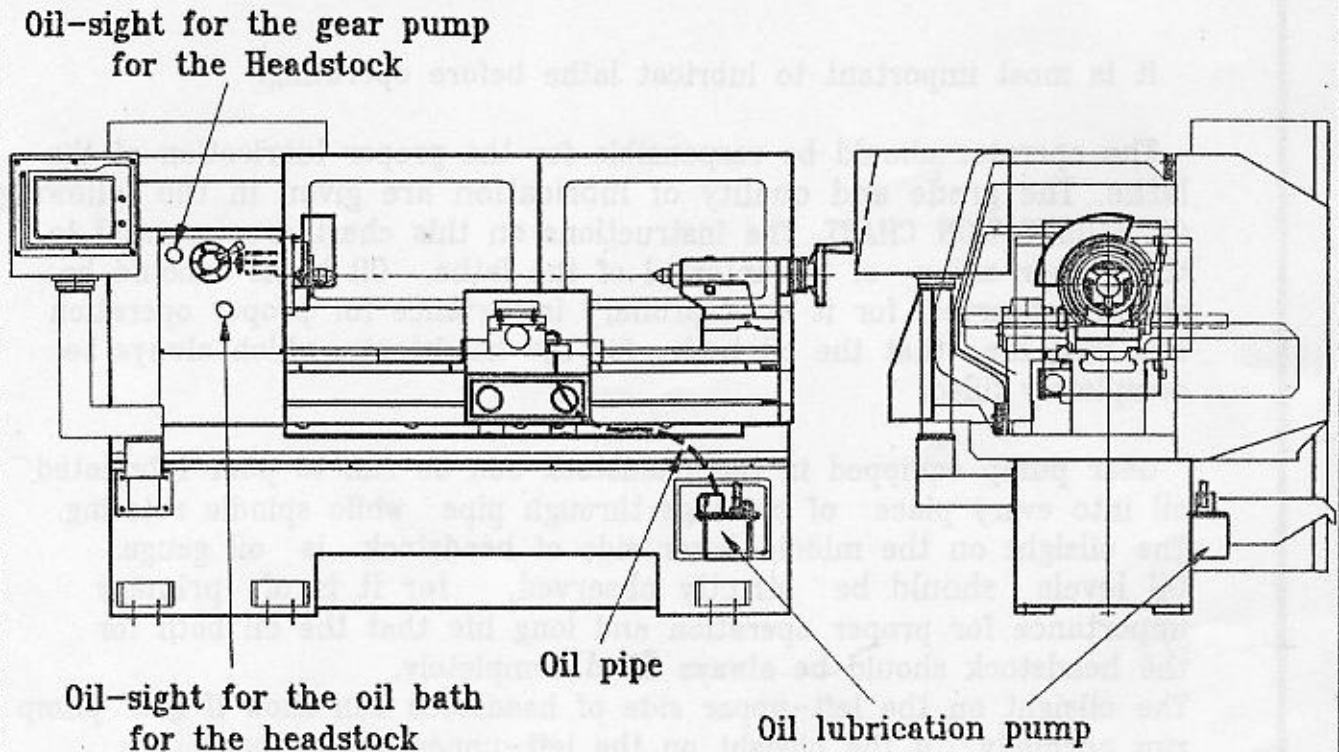

| No. | LUBRICATION POINT | VISCOSITY S.U.S. 100F | OIL RECOMMENDED | OIL EXCHANGE / OR REPLENISHMENT |
|-----|---|--------------------------|-----------------|--|
| 1 | Headstock | 160 | SHELL(TELLUS)25 | Three time a year Keep the oil up to the oil window |
| 2 | Carriage & Cross-slide & Ball screw nut | 320 | SHELL(TONNA)33 | Keep the oil up to the oil window |
| 3 | Tailstock | 320 | SHELL(TONNA)33 | Once a day |

On the tailstock, top of casting and tail end of leadscrew oiler points are provide for daily attention from a standard oil can.

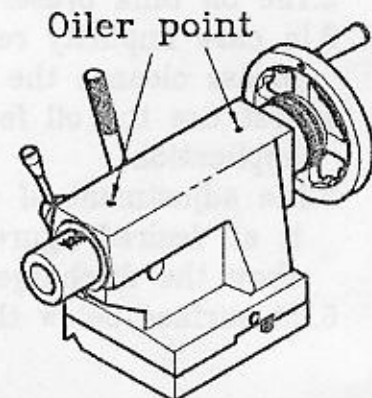

INSTALLATION

CHUCKS AND CHUCK MOUNTING

When mounting chucks or faceplate, first, ensure that spindle and chuck tapers are scrupulously clean and that all cams lock in the correct positions, see Fig. It may be necessary when mounting a new chuck to re-set the camlock studs (A) To do this, remove the cap-head locking screws (B) and set each stud so that the scribed ring (C) is flush with the rear face of the chuck—with the slot lining up with the locking screw hole (see Fig).

Now mount the chuck or faceplate on the spindle nose and tighten the three cams in turn. When fully tightened, the cam lock line on each cam should be between the two V marks on the spindle nose.

If any of the cams do not tighten fully within these limit marks, remove the chuck or faceplate and re-adjust the stud as indicated in the illustration. Fit and tighten the locking screw (B) at each stud before remounting the chuck for work.

This will assist subsequent remounting.

DO NOT INTERCHANGE CHUCKS OR FACEPLATES BETWEEN LATHES WITHOUT CHECKING FOR CORRECT CAM LOCKING BEFOREHAND.

IMPORTANT: Take careful note of speed limitation when using faceplate; 10 inch faceplates should not be run at speeds greater than 1000 rev/min. and 12" faceplate at not more than 770 rev/min.

INSTALLATION

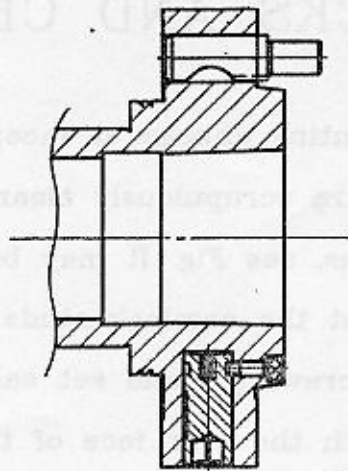

CORRECT

CAM RELEASE DATUM

CAM LOCK LINE
BETWEEN ARROWS

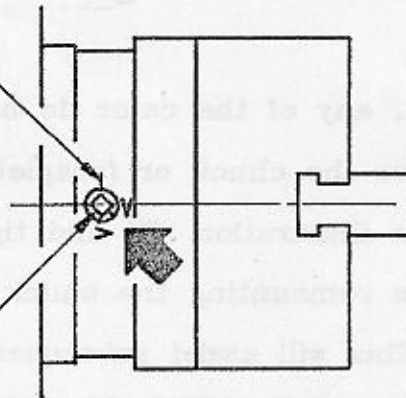

WRONG

TURN
STUD IN
ONE TURN

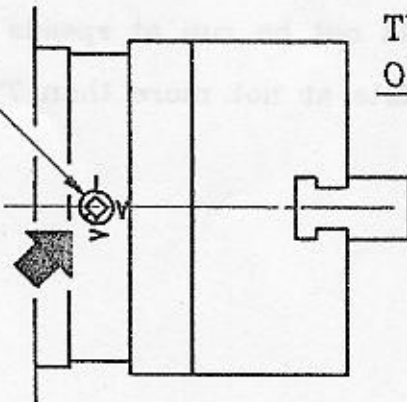

TURN STUD
OUT ONE TURN

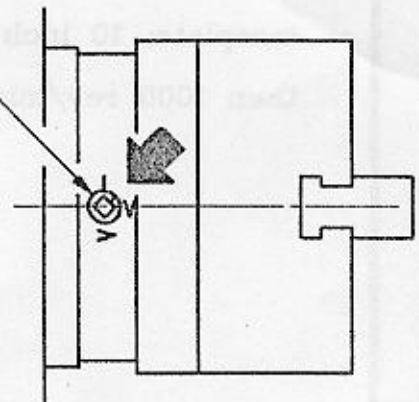

OPERATION

SELECTION OF SPINDLE SPEEDS

Select a appropriate spindle speed for working:
There are three spindle speeds (3 range), from 10 - 2000 rpm, as showed on speed chart, installed in the front of Headstock.

The change of main spindle speeds can be reached by the dial lever, installed in the front of Headstock.

1. Turn lever to make "H" aim at BROAD ARROW, then lathe speed is in HIGH range, 2000~240 r.p.m.
2. Turn lever to make "M" aim at BROAD ARROW, then lathe speed is in MIDDLE range, 380~45 r.p.m.
3. Turn lever to make "L" aim at BROAD ARROW, then lathe speed is in LOW range, 84~10 r.p.m.

In order to obtain the desired spindle speeds, place the lever at the proper position and be sure not to shift the levers when the spindle is running.

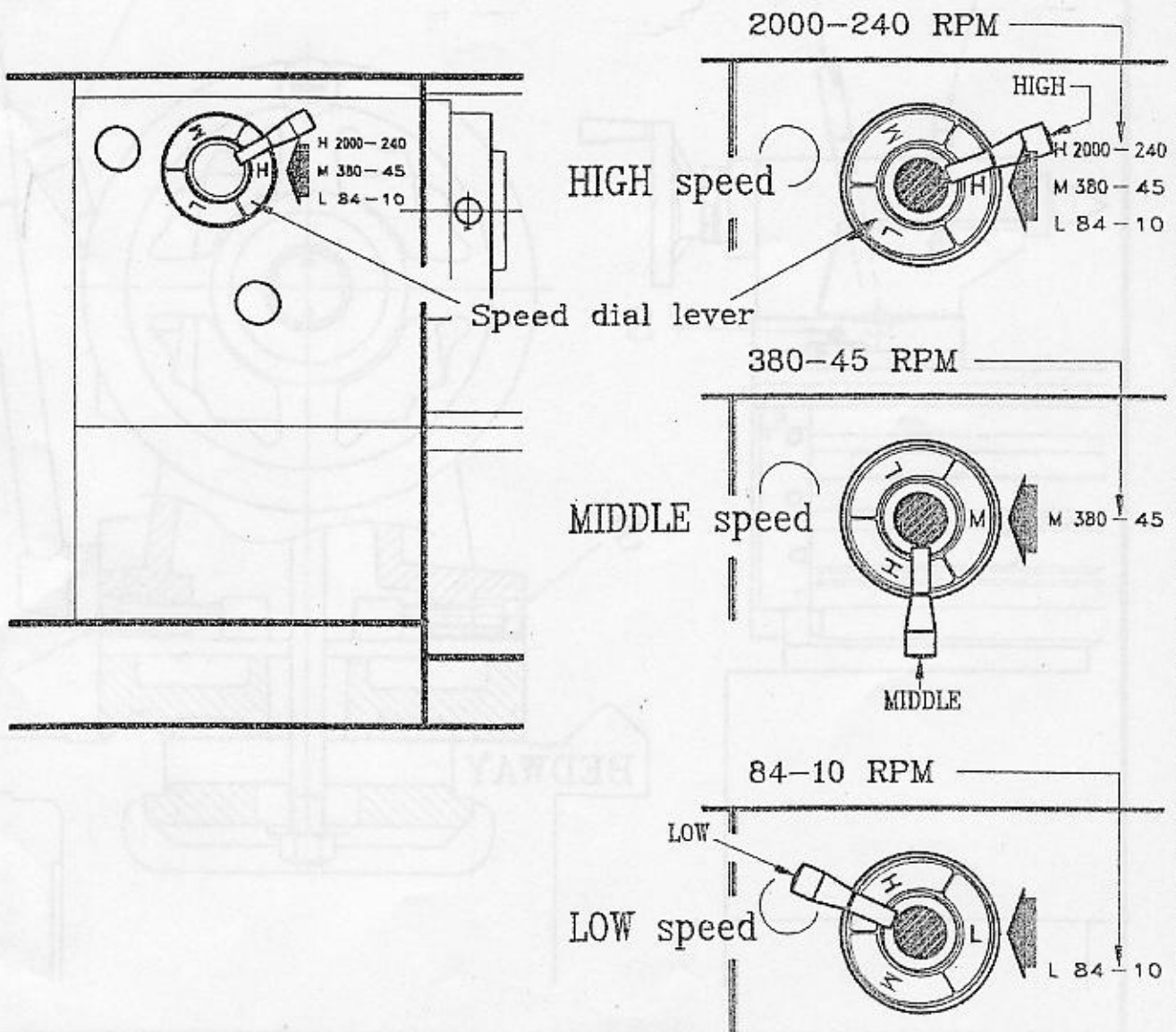

OPERATION

TAIL STOCK

Can be freed for movement along the bed by unlocking the clamp lever (A). The tailstock barrel is locked by lever (B).

The tailstock can be set-over for production of shallow tapers or for re-alignment. Release the clamping lever (A) and adjust screws (S) at each side of the base to move tailstock laterally across the base.

Retightening and checking after adjustment of set over.

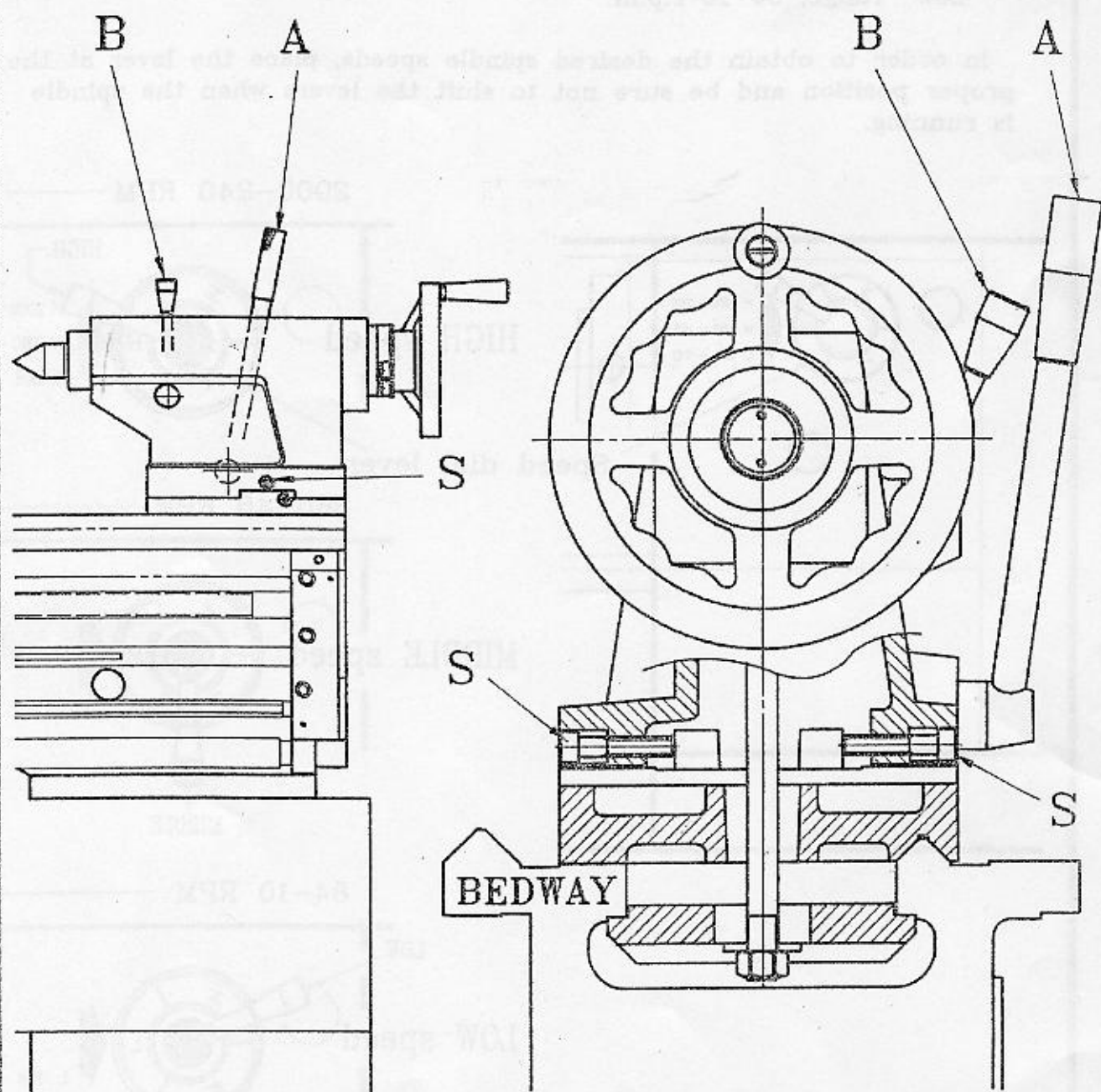

MAINTENANCE

SPINDLE BEARING ADJUSTMENT

If spindle swing too freely or play is noticeable when spindle is pushed back and forth or when the bearings are in the case of bearings noise or chattering or over temperature.

Properly practice adjust middle and front bearing or tightening the adjusting nuts in the headstock.

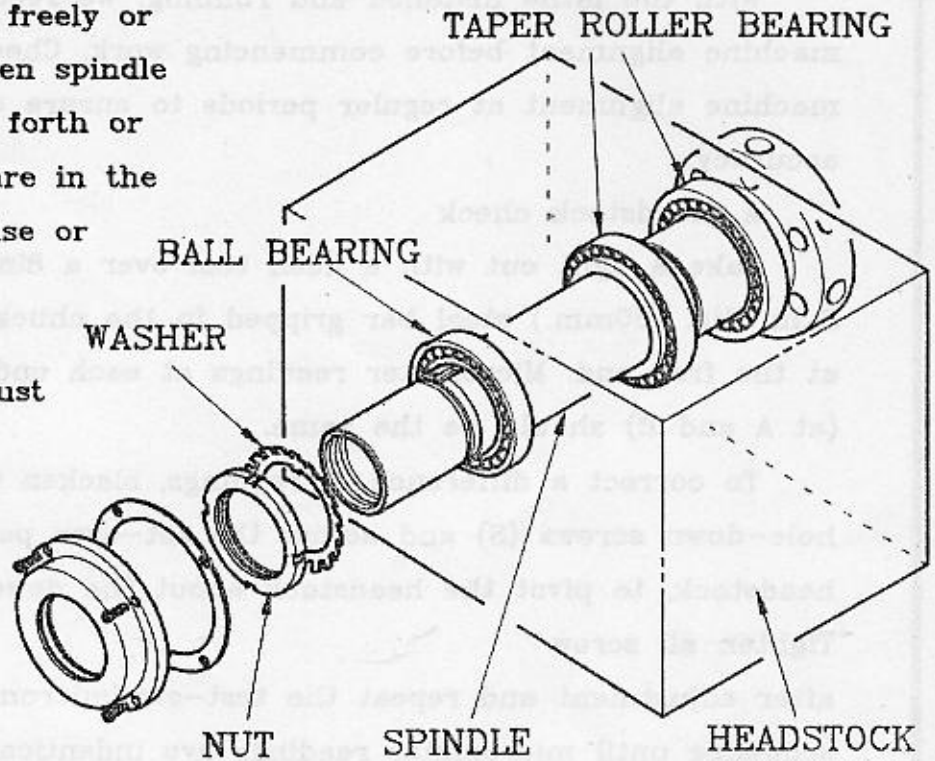

SLIDE WAYS ATTENTION

Tapered gib strips fitted to slideways of saddle and cross-slide so that any slackness which may develop can be rectified.

Ensure that slideways are thoroughly cleaned and lubricated before attempting adjustment. Then reset the gibs by slackening the rear gib screw and tightening the front screw, a little at a time. Check constantly for smooth action throughout full slide travel; avoid overadjustment which can result in increased wear-rate and stiff or jerky action.

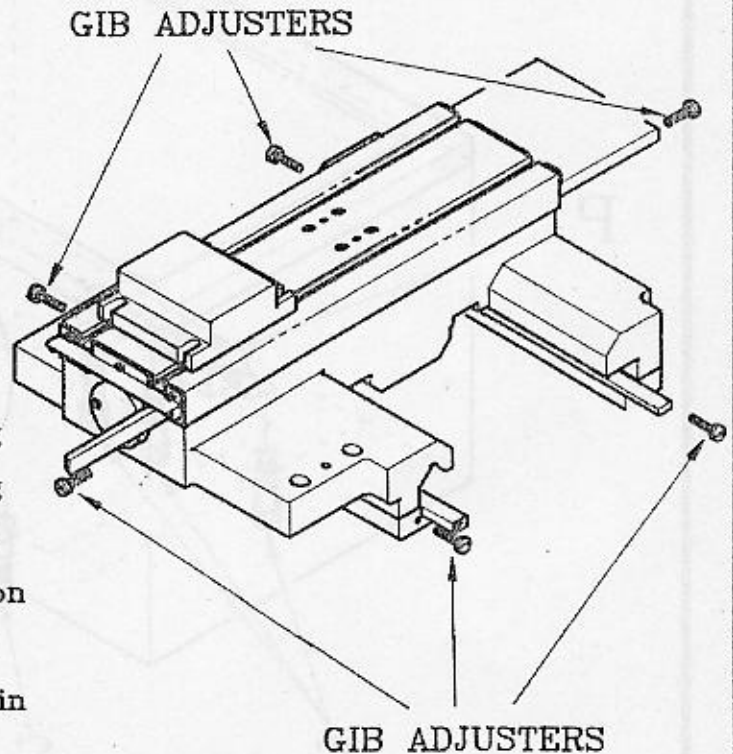

MAINTENANCE

LATHE ALIGNMENT (Part 1)

With the lathe installed and running. We recommend a check on machine alignment before commencing work. Check levelling and machine alignment at regular periods to ensure continued lathe accuracy.

A. Headstock check

Take a light cut with a keen tool over a 8in. (200mm.) length of 2 in. dia. (50mm.) steel bar gripped in the chuck but not supported at the free end. Micrometer readings at each end of the turned length (at A and B) should be the same.

To correct a difference in readings, slacken the five headstock hole-down screws (S) and adjust the set-over pad (P) beneath the headstock, to pivot the headstock about the dowel (D).

Tighten all screw

after adjustment and repeat the test-cut/micrometer-reading,

sequence until micrometer readings are indentical, so machine now cutting absolutely parallel.

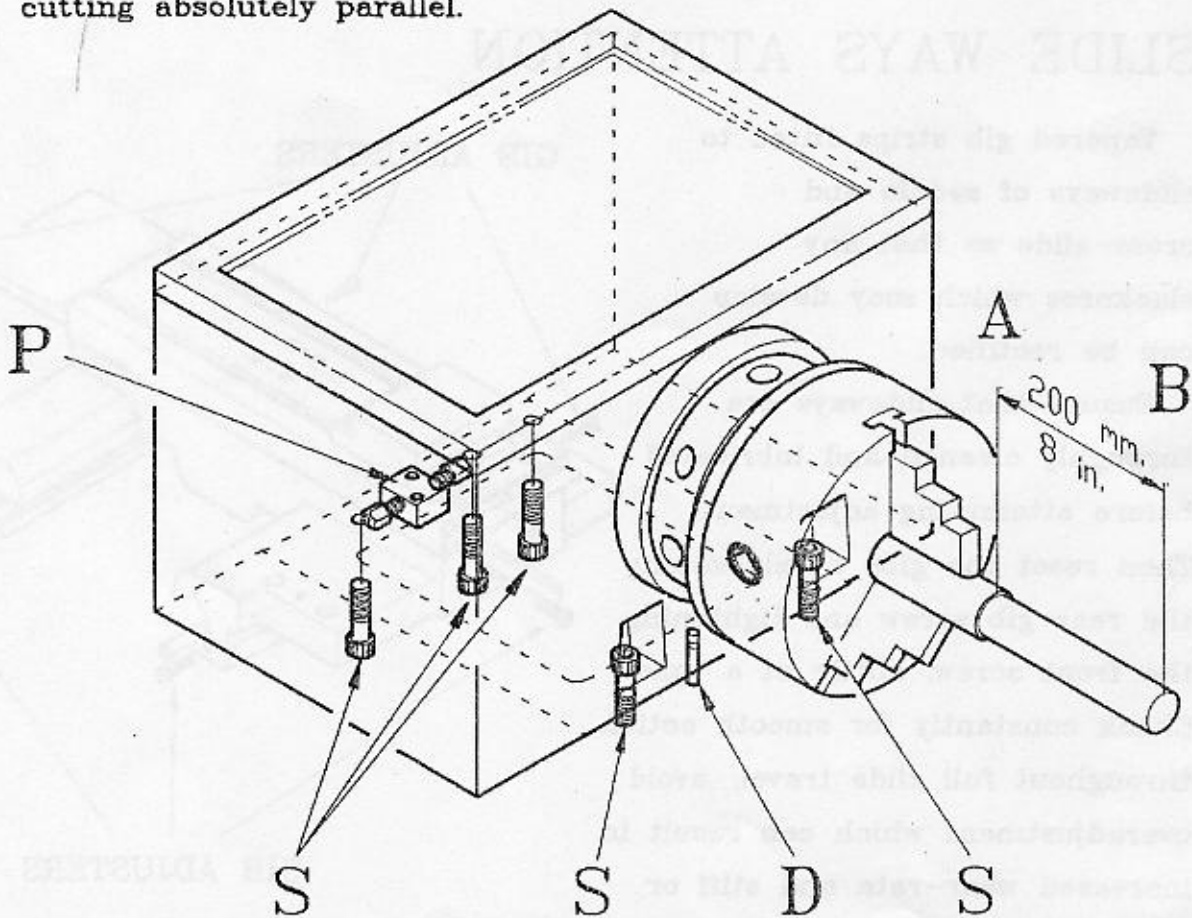

MAINTENANCE

LATHE ALIGNMENT (Part 2)

B. Tailstock check

Using a 12in. (305mm.) ground steel bar fitted between headstock and tailstock centers, check the alignment by fitting a dial-test indicator to the topslide and traversing the center line of the bar.

To correct error release the tailstock clamp lever and adjust the two set-over screws provided continue with checking and correction until the alignment is perfect.

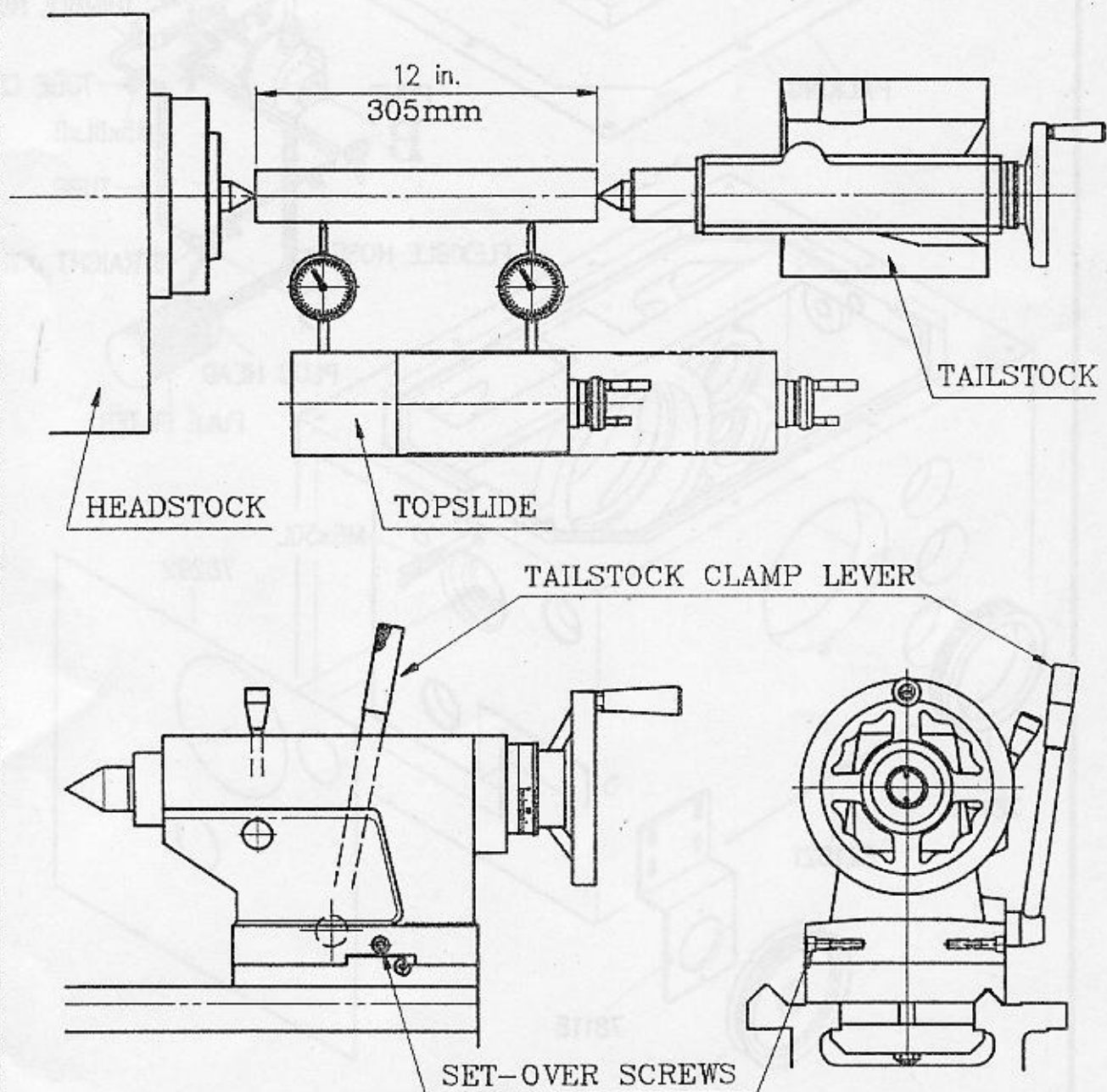

ASSEMBLY HEADSTOCK: CASTING & LUBRICATION SYS.

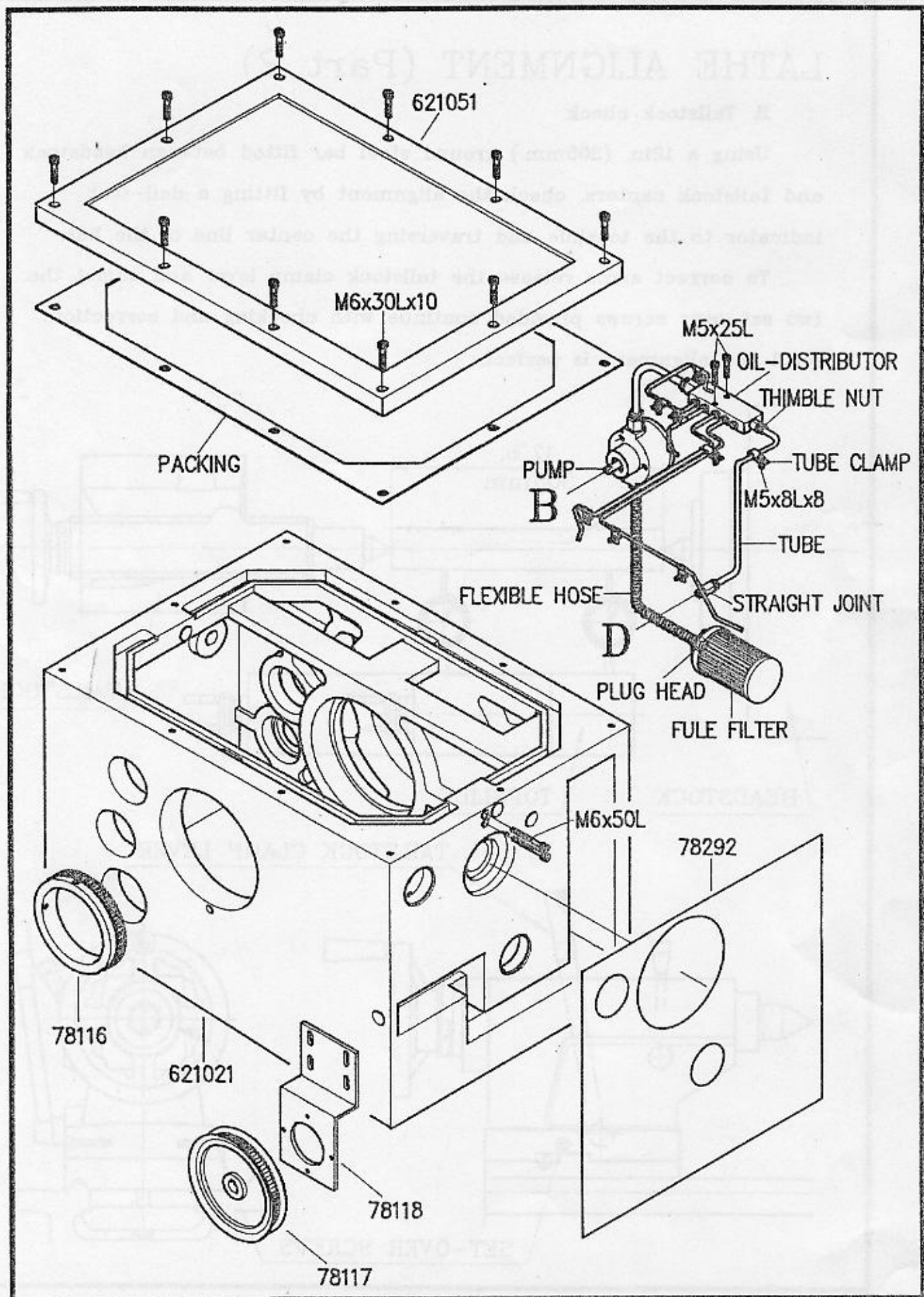

ASSEMBLY HEADSTOCK: SPINDLE SHAFT & GEARS

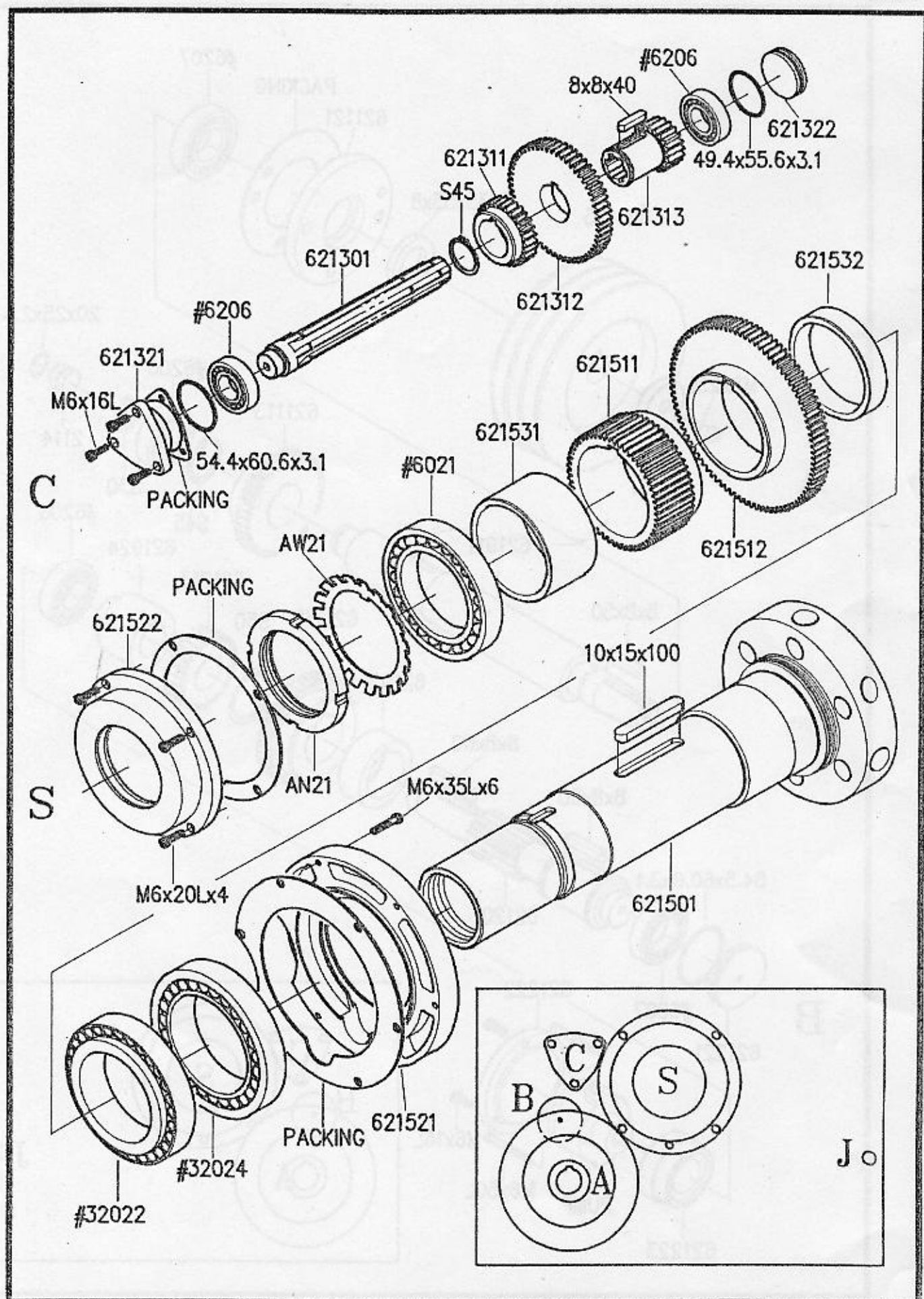

ASSEMBLY HEADSTOCK: CONTROLS

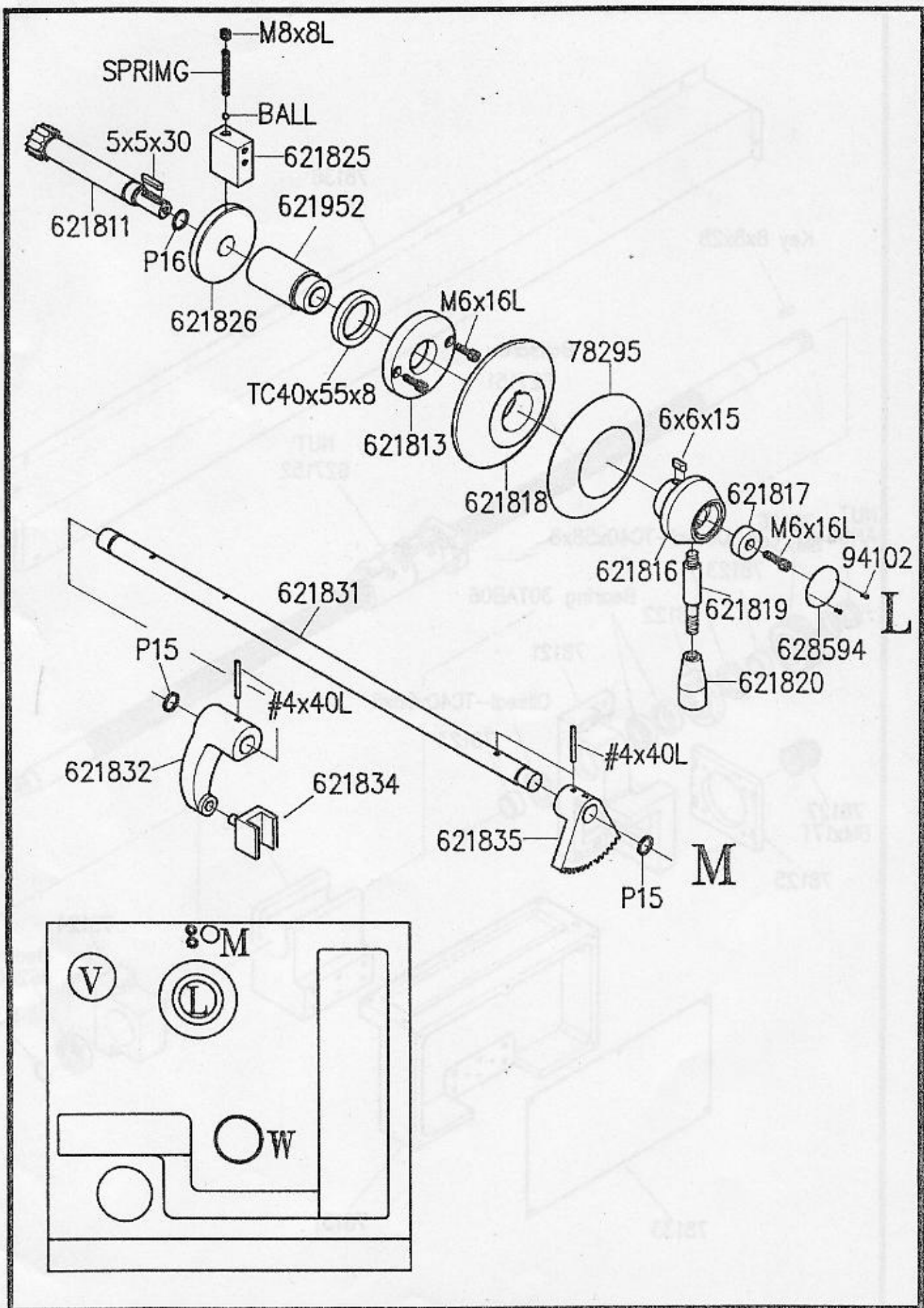

ASSEMBLY Z AXIS BALLSCREW

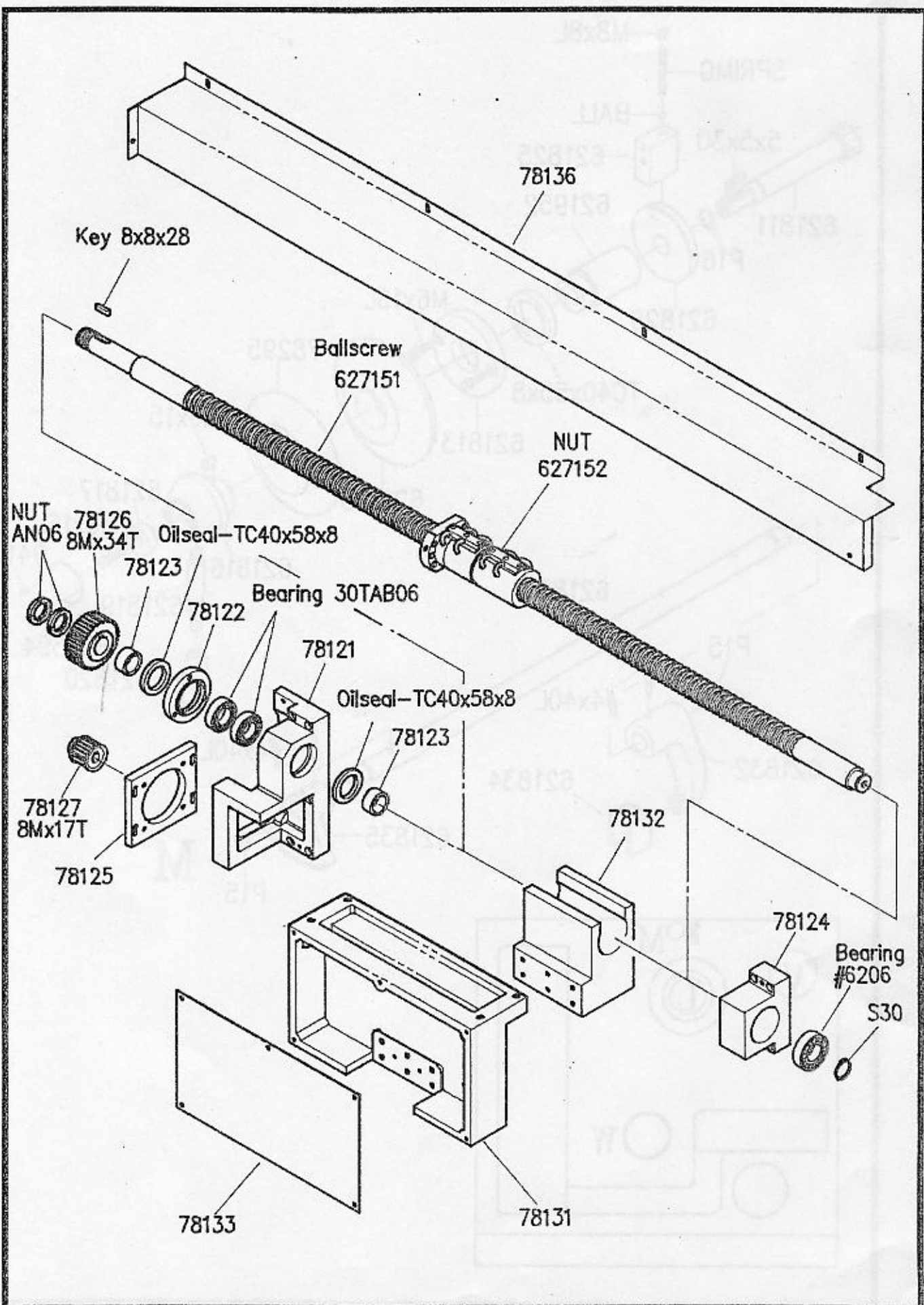

ASSEMBLY SADDLE & CROSS-SLIDE

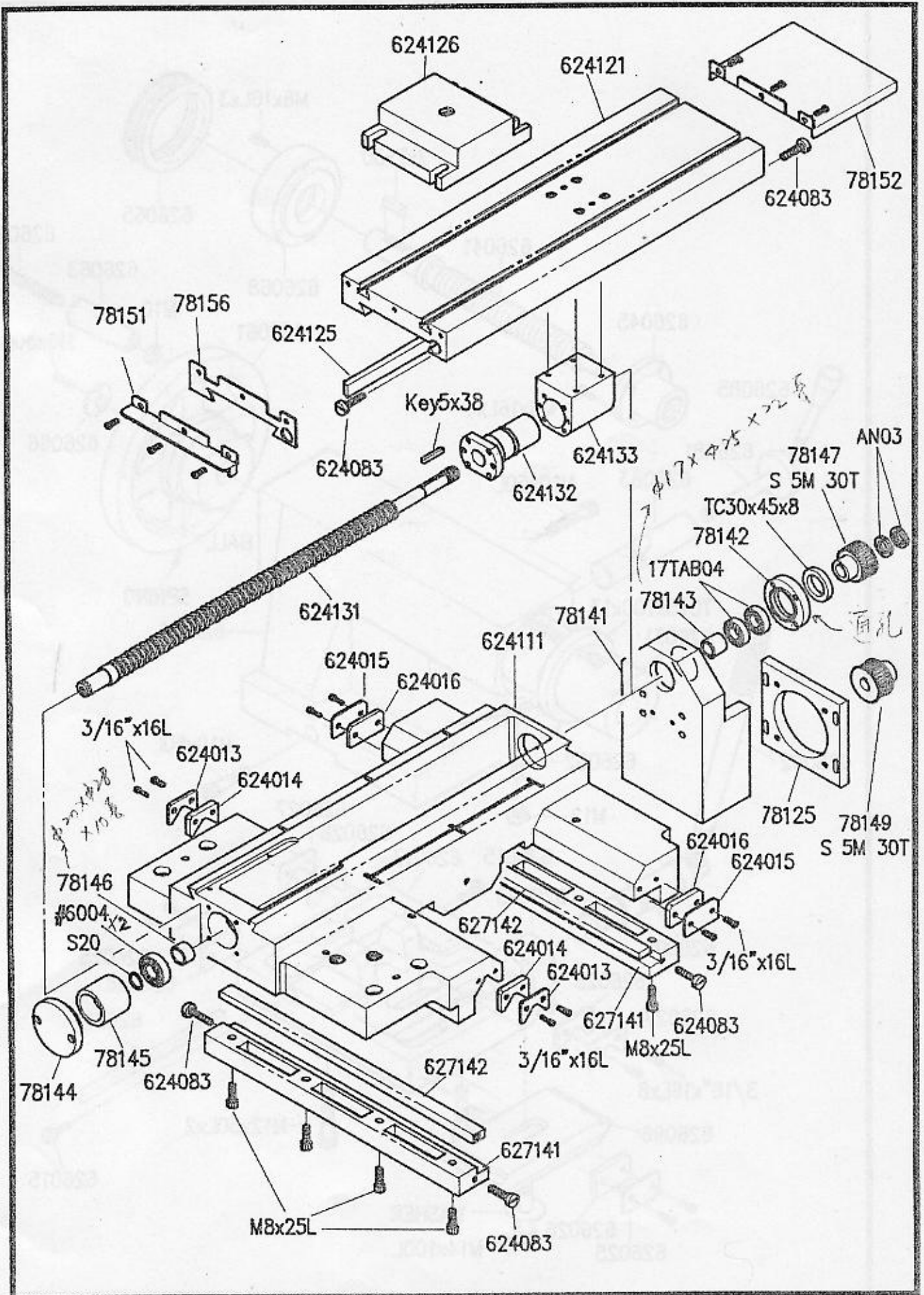

ASSEMBLY TAILSTOCK

