

2. Safety Instructions

Warning :

Do not install, operate, or service this machine until:

- 1) You have read and understand the safety instructions on the pages that follows.
- 2) You have read and understand operator's manual, especially knowing the function and location of all machine controls and read manuals for any related accessories.
- 3) You have read and understand all safety and instruction plates attached to the machine and its related accessories.
- 4) Prior to installing or servicing the machine read and understand maintenance manual. Servicing the machine must be done only by competent and trained personnel.
- 5) American national standard institute (ANSI) standard #B11-6-1984 list many of the responsibilities of a user of turning machines. Your facility should have a copy of this standard and all management, service. And operating personnel concerned with the operation of turning machines should be read and understand its content.

Note:

The operator's manual and maintenance manual, each containing a copy of these safety instructions, should be kept in the vicinity of the machine, so they are accessible to the operators and maintenance personnel.

The following safety measures may be requires for your particular application. Therefore no warranty or representation is offered for absolute correctness or sufficiency of the instructions and some instances of particular applications may be non-inclusive.

2.1 General safety instructions for operating the machine

- 1) The best defense against injuries on a turning machine is to be alert. Never initiate a machine function useless you completely understand what the function will cause the machine to do.
- 2) Never operate the machine with any cover or shield open or removed.
- 3) Never reach into the work area when the spindle is turning or if the machine is in automatic mode.
- 4) Put the machine in the manual mode and be sure last programmed function has been completely before reaching inside of the work area.
- 5) The function of the machine make it impossible to eliminate all pinch points. Be particularly aware of the following pinch points:
 - Spindle and chuck rotation
 - Indexing of turret and tools
 - Carriage and cross-side movement
 - Tailstock movement both quill and body
- 6) Keep machine and area around it clean well lighted. Never allow chips, coolant , or oil to remain on the floor. Do not leave loose objects on or around machine.
- 7) CLOTHING:

Wear safety glasses with eye shields at all times. Protect your eyes. Never use a compressed air hose to remove chips from a machine. Never wear loose fitting clothing. Remove all jewelry (ring, watches, necklaces, etc)

They can be caught in moving parts. Take them off before turning on the machine.

Always wear safety shoes with steel toes and oil-resistant soles.

Wear a safety helmet when working near overhead hazards.

If operator has long hair, hair should always be tucked under a cap or tied back and up.

- 8) Turning machine are designed to be ran by one person. Persons other than the designated operator should stay out of the machine area during operation.
- 9) Take care not to bump or accidentally touch any machine control. Doing so can initiate an unintended machine movement which could cause injury or a wreck.
- 10) Do not paint, alter, deface, or remove any warning plate from the machine. Replacement plates are available for manufacturer.
- 11) Report any loose, worn, or broken parts to your supervisor. The same action should be taken if any unusual noise or machine action occurs.
- 12) Never operate the machine after taking strong medication, using non-prescription drugs, or consuming alcoholic beverages. Person with illness which might cause dizziness or fainting should never operate this machine.
- 13) The electric components are protected from normal moisture resulting from humidity use of water base soluble as coolant, etc. Do not, however, use water hose to clean the machine or the area around it.
- 14) Never touch a machine control device or electrical component when your hand is wet.
- 15) Keep flammable liquids and materials away from the work area and hot chips.
- 16) Never clean up chips while the machine is running or in automatic mode.
- 17) Do not file workpieces being rotated under power
- 18) At the end of the workday, the machine should be placed in either "**CONTROL OFF**" or "**POWER OFF**" modes.
- 19) When restarting a machine after it has been shut down, always assume it has been tampered with. Recheck all phases of the job as though you were running the first piece.
- 20) Never touch spindle start jog control until hands, feet, and body are well clear of the work area.
- 21) Coolant and oils can make surfaces on the machine slippery. They can also present an electrical hazard if the machine has power on. For these reasons do not stand on any part of the machine at any time.
- 22) Never extend an unsupported bar out of the rear of the spindle or hydraulic cylinder a distance from a concentric support more than 10 times its diameter. Doing so can cause the bar to bend or break. When any bar is extended a large sign should be placed to warn people to stay away from the area
- 23) If your turning machine has a barfeeder interfaced to it keep yourself and others away from the exit end of the barfeeder when the machine is running.

2.2 Safety Instructions for Workholding:

1) Never run a job on this machine until you are 100% sure the workpiece is being held in such a manner as to withstand the centrifugal force from rotation and the cutting forces of the tooling. If there is any doubt, whatever, consult with your supervisor.

2) A chuck is the most common workholding device used on the machine. Some of the factors which affect the holding ability of a chuck are:

Clamping force of jaws

Rotational speed of the spindle

Type of jaw surface (serrated, smooth, etc.)

Area of chuck jaws in contact with workpiece

Type of chuck

Configuration of the workpiece ... shape, weight, and balance

Jaw weight and location

3) With air or hydraulic actuated power chucks, make sure the jaws are gripping the workpiece securely before they reach the end of their travel.

When using a power chuck, check the hydraulic or air pressure before every operation low chucking pressures will diminish jaw gripping force which may allow the workpiece to come out of the jaws. Excessive pressure can damage a power chuck, which could cause loss of jaw force. The gripping force of a power chuck can be diminished as much as 50% because the lack of lubrication or lack of periodic cleaning. Components of the chuck are subject to wear and damage which also can lose gripping power

A) Grease the chuck at the beginning of every shift. Use only the chuck manufacturer recommended lubrications.

B) A weekly examination of the condition of the chuck should be made. This examination should include the measurement of jaw clamping force with a jaw force gage to insure that the chuck is functioning as it should.

C) Refer to manufacturer's manual for chuck and cylinder for any other maintenance requirements.

As the spindle rpm increase and the gripping force of the jaw decreases. The larger chuck diameter the more loss becomes.

Various types of top jaw are used on chucks for different applications. For the best workholding conditions use serrated contact surfaces on work gripping surfaces and use maximum area of contact between the jaws and the workpiece.

Improper use cause serious injury or death. Remember chucking a workpiece safety involves many variables. If you have the slightest doubt regarding the safety of your set-up for a job, consult with your supervisor .

4) Never operate spindle mounted accessories above their rated speed. If the chuck or accessory was not supplied by manufacturer of the machine, verify the safe operating speed with the manufacturer.

5) Always be sure the chuck or accessory is located correctly on the spindle nose and it is

securely bolted to the face of the spindle. Turning machines all have ANSI standard type “D1” spindle nose. Chucks or fixtures which are to be mounted must matching ANSI standards type “D1” mounting.

- 6) Be sure any item bolted or clamped to a chuck or fixture is securely fastened before starting the spindle.
- 7) Proper lifting equipment should be used for heavy chucks, fixtures, and workpieces.
- 8) Always be aware that closing chuck jaws can trap fingers or hands.
- 9) The same safety instructions that apply to power chucks also apply to manual operated chucks. The following additional precautions should be taken using a manual chuck:
 - A) Always use spring-loaded, self-ejecting type safety wrenches.
 - B) Never put an extension bar on a chuck wrench or hit it with a hammer.
 - C) Never run a gear scroll chuck without having something chucked in the jaws. Centrifugal force can cause the scroll to unwind if the chuck is empty . If this occurs, the jaw may come out of the chuck while the spindle is turning.
- 10) If a workpiece is extended from the chuck a distance of 3 to 4 times its diameter, without being supported by the tailstock, poor cutting conditions will normal occur. Under no circumstances extend an unsupported workpiece more than this amount without supporting the workpiece with the tailstock. Doing so can cause the part to bend or break.

2.3 MAINTENANCE SAFETY INSTRUCTIONS:

- 1) **WARNING:** High voltage is used to power the machine, only authorized electricians should correct any electrical component failure. Disconnect main power and lock in off position before attempting any repair. Tag disconnect switch **“DO NOT START”**
- 2) Read and understand safety instructions for machine operator before servicing this machine.
- 3) Know all points where high voltage are present on this machine and in electrical boxes.
- 4) Residual voltages can exist in the electrical cabinets for a period of time after power has been turned off. Check any component inside with a meter before touching.

2.4 INSTALLATION SAFETY INSTRUCTIONS:

- 1) Verify machine weight and make sure lifting equipment, cables, etc, are rated at sufficient capacity. Follow directions shown in maintenance manual to lift and move the machine.
- 2) The initial hook-up of the machine to power source must be done by a serviceman. Machines have transformer taps for various line voltages and power cycles. If machine is subsequently moved by the user, the transformer taps must be checked to insure they are wired correctly for new location.
- 3) A copper (5/8” min. dia.) rod must be sunk through foundation into the earth at the

machine Length should be sufficient to provide less than 80 ohms resistance between the end of the rod and earth ground. A large copper wire must directly connect this earth ground, ground connection provided on the machine.

- 4) If the slightest doubt concerning safety procedures arises, call the local distributor.

2.5 INSTALLATION PRECAUTIONS

To ensure the safe operation of the NC machine, note the following during installation:

2.5.1 Wiring

- 1) Be sure to use electrical conductors with performances ratings equivalent or superior to those described in the Maintenance Manual.
- 2) Do not connect to the power distribution panel any power cables for devices which can cause line noise, such as are welders and high frequency quenching machines.
- 3) Arrange for a qualified electrical engineer to connect the power lines.

2.5.2 Grounding

Use a grounding wire with a cross section of more than 14mm^2 and a resistance to ground of less than 100 ohms.

This wire size should be greater than AWG (American Wire Gauge) NO.5 and SWG(British Legal Standard Wire Gauge) NO.6

Generally, the NC machine should be grounded to a separate grounding rod. If an independent ground can not be provided for the machine, prepare the ground connection as follows:

- 1) Connect a single conductor to its own grounding terminal. This will avoid possible serious accidents resulting from ground currents which might otherwise flow in the NC machine if a peripheral device should malfunction.
- 2) Be careful when using concrete reinforcing rods as grounding points. These reinforcing rods often are used to ground equipment because they usually offer a resistance to ground of less than 100 ohms/ In doing so, make the connection as follows:
This also applies to connecting ground wires to regular grounding terminals.
 - a. Do not use the same grounding reinforcing rod or grounding terminal for other devices since this could lead to line noise such as produced electric welders and high frequency quenching machines.
 - b. Use a grounding terminal with an adequate electrical performance rating and which is durable.
- 3) A separate grounding wire should be used, one whose length is as short as possible.
- 4) Check the resistance to ground by actual measurement.
This should measure less than 100 ohms if the single device is connected to its own grounding rod.

Desirable Independent Grounding:

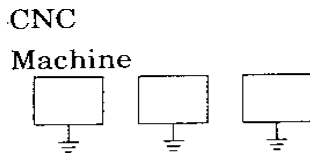

Earth resistance:
Less than 100 ohms

Common Grounds:

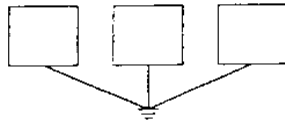

Resistance to
ground= $100/\text{the}$
number of devices
connected to
the grounding (Ω)

Never ground equipment as shown in the following figure:

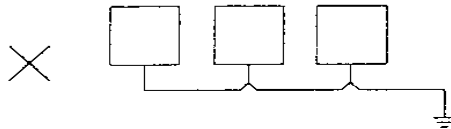

2.5.3 Environmental Conditions

Generally, the machine will be installed on the following conditions. However, these may change over a period of time or in response to seasonal changes.

- 1) Supply voltage : $\pm 10\%$ of normal supply voltage
- 2) Source frequency : ± 2 Hz of normal frequency
- 3) Ambient temperature : 0°C to 45°C (32°F to 113°F)
- 4) Relative Humidity : Less than 80% temperature changes should not cause condensation
- 5) Atmosphere : free from excessive dust, acid fumes corrosive gases and salt
- 6) It should be avoided to expose the machine to direct sunlight or hit rays which can change the environmental temperature
- 7) Avoid exposing the NC machine to abnormal vibration
- 8) Keep away from the location of powdering dust environment.
- 9) Keep away from the location where acid, alkali and salty air or liquid is generated.
- 10) Keep away from the magnetic and static environment.
- 11) Keep away from larger air compressor or punching machine.
- 12) Keep away from electrical noise noise source and sparker (such as welding, E.D.M machines)

2.6 SAFETY PRECAUTIONS

These machine is provide with a number of safety devices to protect personnel and equipment from injury and damage.

Operators should not, however, rely solely upon these safety devices but should

operate machine after fully understanding what special precautions to take by reading the following remarks throughly

2.6.1 Basic Operating Practices

DANGER:

- 1) Some control panel, transformers, motor, junction boxes and other parts have high voltage terminals, these should not be touched or a severe electric shock will be sustained.
- 2) Do not touch a switch with wet hands. This, too, can produce an electric shock.

WARNING:

- 1) The emergency stop push-button switch location should be well known so that, it can be operated at any time without having to look for it.
- 2) Before replacing a fuse, switch off the machine.
- 3) Provide sufficient working spaces to avoid hazardous falls
- 4) Water or oil can make floors slippery and hazardous. To prevent accidents all floors should be dry and clean.
- 5) Before operating switches always check that they are the right ones.
- 6) Never touch a switch accidentally.
- 7) Work benches near the machine must be strong enough. To prevent accident, Articles should be prevented from slipping off the bench surface.
- 8) If a job is to be done by two or more persons, coordinating signals should be given at each step of the operation. Unless a signal is given and acknowledged, the next step should not be taken.

CAUTION:

- 1) In the event of power failure, turn off the main circuit breaker immediately.
- 2) Use the recommendend hydraulic oils, lubricants and grease or acceptable equivalents.
- 3) Replacement fuses should have the proper current ratings
- 4) Protect the NC unit, operating panel, electric control panel, etc. from shocks since this could cause a failure or malfunction.
- 5) Do not change parameter, volumes and other electrical setting unnecessarily. If such changes are unavoidable, record the values prior to the change so that they can be returned to their original settings if necessary.
- 6) Do not soil, scratch or remove the caution plate. Should it become illegible or be missing, order another caution plate from the supplier specifying the part number shown at the lower right of the plate.

2.6.2 CONNECTION OF POWER LINE

- (1) Make sure the power voltage is same as machine voltage.
- (2) The main power line can be connected into the electric box to be tightened to the terminal through the button of the box.
- (3) Use 4 cords and the cross sectional area is at least 4.0 mm² for the power line, connected to ground and over voltage protector according to the local electricity regulations.
- (4) For wiring to different voltage, be sure to rewire hydraulic pump motor, spindle motor and transformer to the correct voltages. And to replace fuses to protect the electrical component. Using the current chart as refer to part X, or contact our agents for detail.

Note: Do not use machine if its voltage preset is different from external power supply. Contact electric technician for reparation if necessary.

2.6.3 Before Switching On:

DANGER:

Cables cords or electric wires whose insulation is damaged can produce current leaks and electric shocks. Before using these, check their condition.

WARNING:

- 1) Be sure the instruction manual and the programming manual are fully understood. Every function and operating procedure should be completely clear.
- 2) Use safety hose which are not damaged by oil, safety goggles with side covers, safe clothes and other safety protection.
- 3) Close all NC unit, operating panel and electric control panel doors and covers.

CAUTION;

- 1) The power cable from the factory feeder switch to the machine main circuit breaker should have a sufficient sectional area to handle the electric power used.
- 2) Cables which must be laid on the floor must be protected against chips so that short-circuits will not occur.
- 3) Before first operating the machine after unpacking or keeping the machine idle for a long period (several or more), each sliding part must be freshly lubricated. For the lubricating and so forth, keep lubricating oil pump working until, oil oozes out from wiper.
- 4) Oil reservoirs should be filled to indicated levels. Check and add oil, if necessary.
- 5) For lubricating points, oil brands and appropriate levels, see the various instruction plates.
- 6) Switch and levers should operate smoothly. Check that they do.
- 7) When switching the machine on, put the factory feeder switch, the machine main circuit

breaker and the power switch on the operating panel to the ON position in that order.

8) Check the coolant level, and add coolant, if necessary.

2.6.4 After Control Power Switch Has been Turned On

CAUTION:

When the power switch on the operating panel is ON as described in 7 above, the READY lamp should also be on; check that it is.

2.6.5 Routine Inspections

WARNING:

When checking belt tensions, do not get your fingers caught between the belt and pulley.

CAUTION:

- 1) Check pressure gages for proper reading.
- 2) Check motors, gear boxes and other parts for abnormal noise.
- 3) Check the motor lubricant, and sliding parts for evidence of proper lubrication.
- 4) Check safety covers and safety devices for proper operation.
- 5) Check belt tensions. Replace any set of belts that has become stretched with a fresh matching set.

2.6.6 Warm Up

- 1) Warm up the machine, especially the spindle and feed shaft by running them for 10 to 20 minutes at about half or one-third the maximum speed in the automatic operation mode.
- 2) This automatic operation program should cause each machine component to operate. At the same time, check their operation.
- 3) Be particularly careful to warm up the spindle which can turn above 2500rpms. If the machine is used for actual machining immediately after being started; following long idle period, sliding parts may be worn due to lack of oil. Also, thermal expansion the machine components can jeopardize machining accuracy. To prevent this condition always warm the machine up.

2.6.7 Preparations

WARNING:

- 1) Tooling should conform to the machine specifications, dimensions and types.
- 2) Seriously worn tools can cause injuries. Replace all such tools with new ones.
- 3) The work area should be adequately lighted to facilitate safety check.
- 4) Tools and other items around the machine or equipment should be stored to ensure good footing and clear aisles.
- 5) Tools or any items must not be place on the headstock, turret, cover and similar places.
- 6) If the center holes of heavy cylindrical workpiece are too small, the workpiece can jump

out when loaded. Be careful about center holes and angles.

CAUTION:

- 1) Tool length should be within specified tolerances to prevent Interference.
- 2) After installing a tool, make a trial run.

2.6.8 Operation

WARNING:

- 1) Do not work with long hair that can be caught by the machine. Tie it up at the back ,
out of the
way.
- 2) Do not operate switches with gloves on. This could cause malfunction, etc.
- 3) Whenever a heavy workpiece must be moved, two or more persons should always
work
together otherwise risk is involved.
- 4) Only trained, qualified workers should operate forklift trucks, cranes or similar
equipment and
apply slings.
- 5) Whenever operating a forklift truck, crane or similar equipment, special care should
be taken to
prevent collision and damage to surroundings.
- 6) Wire ropes or slings should be strong enough to handle the loads to be lifted and
should
conform to the mandatory provisions
- 7) Grip workpiece securely.
- 8) Stop the machine before adjusting the coolant nozzle at the tip.
- 9) Never touch a turning workpiece or spindle with bare hands or in any other way.
- 10) While a workpiece is turning, do not wipe it off or remove chips with a cloth or by and.
always stop the
machine first and then use a brush and sweeper.
- 11) Do not operate the machine with safety front and chuck covers removed.
- 12) Use a brush to remove chips from the tool tip-not bare hands.
- 13) Stop the machine whenever installing or removing a tool.
- 14) Whenever machining magnesium alloy parts, wear a protective mask.

CAUTION:

- 1) During automatic operation, never open the machine door.
- 2) When performing heavy-duty machining, carefully prevent chips from being accumulate
since hot chips can catch fire.

2.6.9 To Interrupt Machining

WARNING:

When leaving the machine temporarily after completing a job. Turn off the power switch on the operation panel and the main circuit breaker.

2.6.10 Completing a Job

CAUTION:

- 1) Always clean the machine or equipment, Remove and dispose of chips and clean cover windows, etc.
- 2) Do not clean the machine or equipment before it has stopped.
- 3) Return each machine component to its initial condition.
- 4) Check wipes for breakage. Replace broken wipers.
- 5) Check coolant, hydraulic oil and lubricant for contamination. Change them if they are seriously contaminated.
- 6) Check coolant, hydraulic oil and lubricant levels. Add, if necessary.
- 7) Clean the oil pan filter.
- 8) Before leaving the machine at the end of the shift, turn off the power switch or operating panel, main circuit breaker and factory feeder switch in that order.

2.6.11 Safety Devices

- 1) Front sliding doors, rear cover , chuck guarding and coolant cover
- 2) Over travel limit switches
- 3) Chuck barrier, tail barrier and tool barrier (NC software)
- 4) Stored stroke limit (NC software)
- 5) Emergency stop push-button switch

2.6.12 Preparations Before Maintenance

- 1) Do not proceed to any maintenance operation unless instructed to do so by the foreman.
- 2) Replacement parts, consumables (packing, oil seals, O rings, bearing, oil and grease etc.) should be arranged in advance.
- 3) Prepare to record preventive and corrective maintenance operations.

CAUTION:

- 1) Thoroughly read and understand the safety precautions in the instruction manual.
- 2) Thoroughly read the whole maintenance manual and fully understand the principles construction and precautions involved.

2.6.13 Maintenance & Service

DANGER:

1) Those not engaged in the maintenance work should not operate the main circuit breaker or the control power

ON switch on the operating panel. For this purpose, “Do not Touch the Switch, Maintenance Operation in

Progress” or similar working should be indicated on such switches and at any other appropriate locations,

Such indication should be secured by a semi-permanent means in the reading direction.

2) With the machine turned on, any maintenance operation can be dangerous, In principle, the main circuit

breaker should be turned off throughout the operation.

WARNING:

1) The electrical maintenance should be done by a qualified person or by others competent to do the job. Keep close contact with the responsible person. Do not decide by yourself.

2) Overtravel limit and proximity switches and interlock mechanisms including functional parts should not be removed or modified.

3) When working at a height, use steps or ladders which are maintained and controlled daily for safety.

4) Fuses, cables, etc, made by qualified manufacturers should be employed.

2.6.14 Until Operation is Begun at Maintenance

WARNING:

1) Arrange things in order around the section to receive the maintenance, including working environments. Wipe water and oil off parts and provide safe working environment.

2) All parts and waste oil should be removed by the operator and placed far enough away from the machine to be safe.

CAUTION:

1) The maintenance person should check that the machine operates safely.

2) Maintenance and inspection data should be recorded and kept for reference.

2.7 WARNING SIGN PLATES ON THE MACHINE

Safety-related information, that must be strictly observed by all machine operators is given on warning sign plates. These warning sign plates are attached to the machine.

3. Specifications

Specifications for CNC Heavy Duty Teach-in Lathes

Description Model	KL-2660 / KL-2680 KL-26120 / KL-26160 KL-26200 / KL-26240	KL-3060 / KL-3080 KL-30120 / KL-30160 KL-30200 / KL-30240	KL-3260 / KL-3280 KL-32120 / KL-32160 KL-32200 / KL-32240		
WORKING CAPACITY					
Swing over bed	670 mm	770 mm	840 mm		
Center height to bed	335 mm	385 mm	420 mm		
Center height to top cross slide	205 mm	250 mm	280 mm		
Swing over cross slide	400 mm	500 mm	570 mm		
Dis. Between centers	1600 mm / 2100 mm / 3100 mm 4100 mm / 5100 mm / 6000 mm	1600 mm / 2100 mm / 3100 mm 4100 mm / 5100mm / 6000 mm	1600 mm / 2100 mm / 3100 mm 4100 mm / 5100mm / 6000 mm		
Width of bed	450 mm				
HEADSTOCK					
Spindle nose	D1-8 *	A2-11 *	A2-11	A2-15	A2-20
Spindle bore	85 mm (3.34")	105 mm (4")	153 mm (6") opt	230 mm (9") opt	305 mm (12") opt
Spindle speeds range	H: 2000 - 491 rpm M: 490 – 126 rpm L: 125 – 25 rpm	H: 1500 - 331 rpm M: 330 – 93 rpm L: 92- 24 rpm	H: 800 - 176 rpm M: 175 – 59 rpm L: 58- 12 rpm	H: 450 - 108 rpm M: 107 - 31rpm L: 30- 6rpm	H: 350 - 87rpm M: 86- 26rpm L: 25- 5rpm
Taper in spindle	MT#5				
SADDLE					
Longitudinal travel (Z-axis)	1300 mm / 1800 mm / 2800mm 3800 mm / 4800mm / 5800 mm	1300mm / 1800mm / 2800mm 3800mm / 4800mm / 5800 mm	1300mm / 1800mm / 2800mm 3800mm / 4800mm / 5800 mm		
Cross-slide travel	450 mm	450 mm	450 mm		
Size of tool holder	25 mm	32 mm	32 mm		
Ball screw (Dia x pitch)	X-Axis: Ø25mm x P 5mm, Z-Axis: Ø50mm x P10mm				
TAILSTOCK					
Quill Diameter	Ø 105 mm	Ø 105 mm	Ø 105 mm		
Quill Travel	220 mm	220 mm	220 mm		
Quill Taper	MT #5	MT #5	MT #5		
MOTOR					
Spindle motor	20 HP (Std.), 30 HP (option)				
Z-axis drive motor	12 Nm (FKM 44.3)				
X-axis drive motor	6.3 Nm (FKM 42.3)				
Coolant pump motor	1/4 HP				
X, Z- AXES FEED					
X axis rapid travel	6 M /min				
Z axis rapid travel	8 M /min				
GENERAL					
Power Required	20 KVA				
Floor space (L x M x H)	3590/4090/5090/6090/7090 x 1950 x 1820 mm				
Approx, machine	3500kgs / 4500kgs /	4000kgs / 4700kgs /	4300kgs / 5000kgs / 5700kgs		

weight	5000kgs 5500kgs / 6200kgs / 7000 kgs	5200kgs 5700kgs / 6400kgs / 7200 kgs	6000kgs / 6700kgs / 7500 kgs
--------	--	--	---------------------------------

- **KL-2600 Series Spindle with D1-8, Ø85 mm Spindle bore as a standard, KL-3000 and KL-3300 Series Spindle with A2-11, Ø 105 mm Spindle bore as a standard.**
- Specifications are subject to change without prior notice.
- Actual working travel maybe reduced by Hydro. Turret and Chuck option are fitted.

STANDARD EQUIPMENT:

- FAGOR 8055TC Teach-in CNC Control
- Two electric hand-wheels for X-Z axes
- Coolant system
- Automatic Lubrication
- *Cycle stop light tower indicator*
- Fully enclosed guarding with interlock sliding doors
- Manual Tailstock
- Manual 4-way tool post
- Halogen work light
- Instruction manual and tools box & tool kits

OPIONAL EQUIPMENT:

- SINUMERIK 810D w/ManualTurn with 10" color LCD
- FANUC 0i mate TC with 7.2" LCD
- FANUC 0i TC w/Manual Guide w/7.2" LCD
- ANILAM 4200T CNC Control with 14" color LCD.
- 3-jaw screw chuck (Manual), 16", 20"
- Hydraulic pump unit for chuck & Turret.
- Hydraulic chuck w/rotary cylinder.
- 8 station Turret.
- 12 station Turret.
- Quick change tool post with 6 holder
- 9", 12" or 14" Spindle bore
- Dual chuck option (factory installation)
- Chip conveyor.
- Steady rest w/roller Type.(φ 160- φ 360mm)
- Follow rest.(φ 40- φ 250 mm)

4. Installation

4.1 Selection of location

To upgrade the operation efficiency and accuracy of precision machine, a proper foundation is required.

It is recommended to locate CNC Teach-in Lathe Machines in a plant with permanent temperate (about 20°C) and without the influence of damping, chemical gas or trembling. The machine body is not allowed to be exposed to sunshine or rains.

Please be sure not to install the machines adjacent to Punching machine, Welding machine, Spark EDM machine. Otherwise. It will result in poor performance.

A distance of at least 850mm is required from machine to wall and objects or between machines as well as easy opening of the door of electric cabinet.

4.2 Diagram of minimum space for KL-2600, KL-3000 & KL-3200 Series

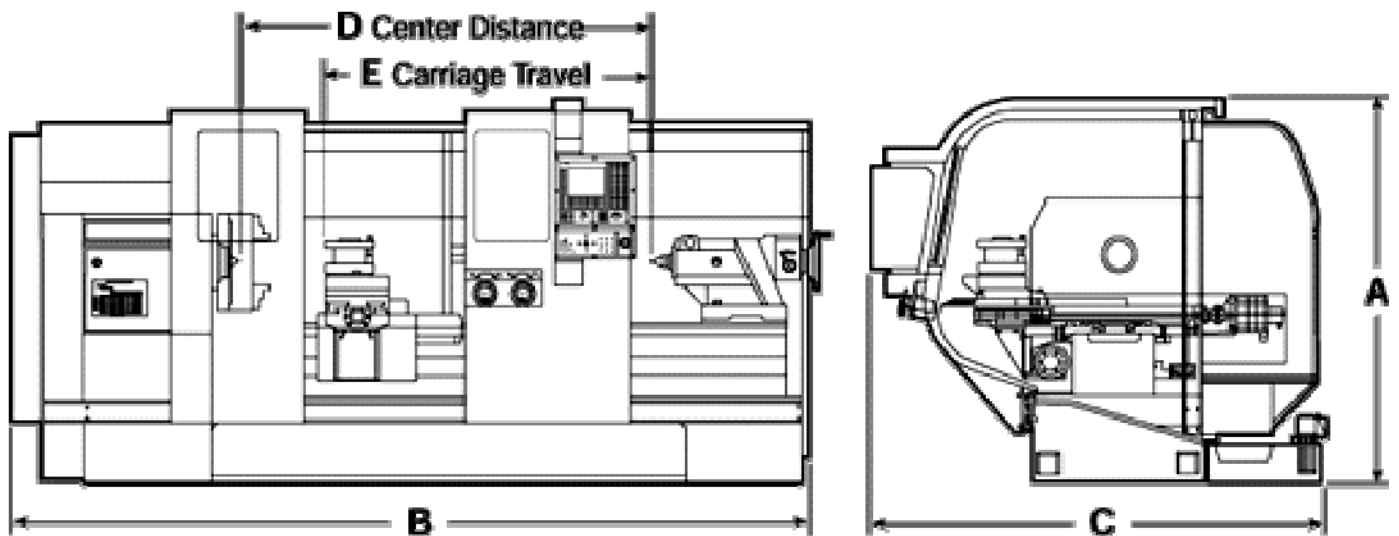

Model	A	B	C	D	E	Weight
KL-2660	1900 mm	3420 mm	2000 mm	1500 mm	1200 mm	5200 Kgs
KL-3060	(74.8")	(126")	(78.7")	(60")	(47.2")	
KL-3080	1900 mm	3920 mm	2000 mm	2000 mm	1700 mm	5400 Kgs
KL-3080	(74.8")	(154")	(78.7")	(80")	(67")	
KL-30120	1900 mm	4920 mm	2000 mm	3000 mm	2700 mm	6000 Kgs
KL-30120	(74.8")	(193.7")	(78.7")	(120")	(106")	
KL-3260	1900 mm	3420 mm	2000 mm	1500 mm	1200 mm	5400 Kgs
	(74.8")	(126")	(78.7")	(60")	(47.2")	
KL-3280	1900 mm	3920 mm	2000 mm	2000 mm	1700 mm	5800 Kgs
	(74.8")	(154")	(78.7")	(80")	(67")	
KL-32120	1900 mm	4920 mm	2000 mm	3000 mm	2700 mm	6300 Kgs
	(74.8")	(193.7")	(78.7")	(120")	(106")	

4.3 Foundation

(a) With special torque-resistant capability at the base, this machine requires no particular foundation. Only provide 15cm thick of concrete on the floor and leave space for components adjustment for leveling. (Refer to figure 5) for foundation diagram.

26/30/32 - 60/80

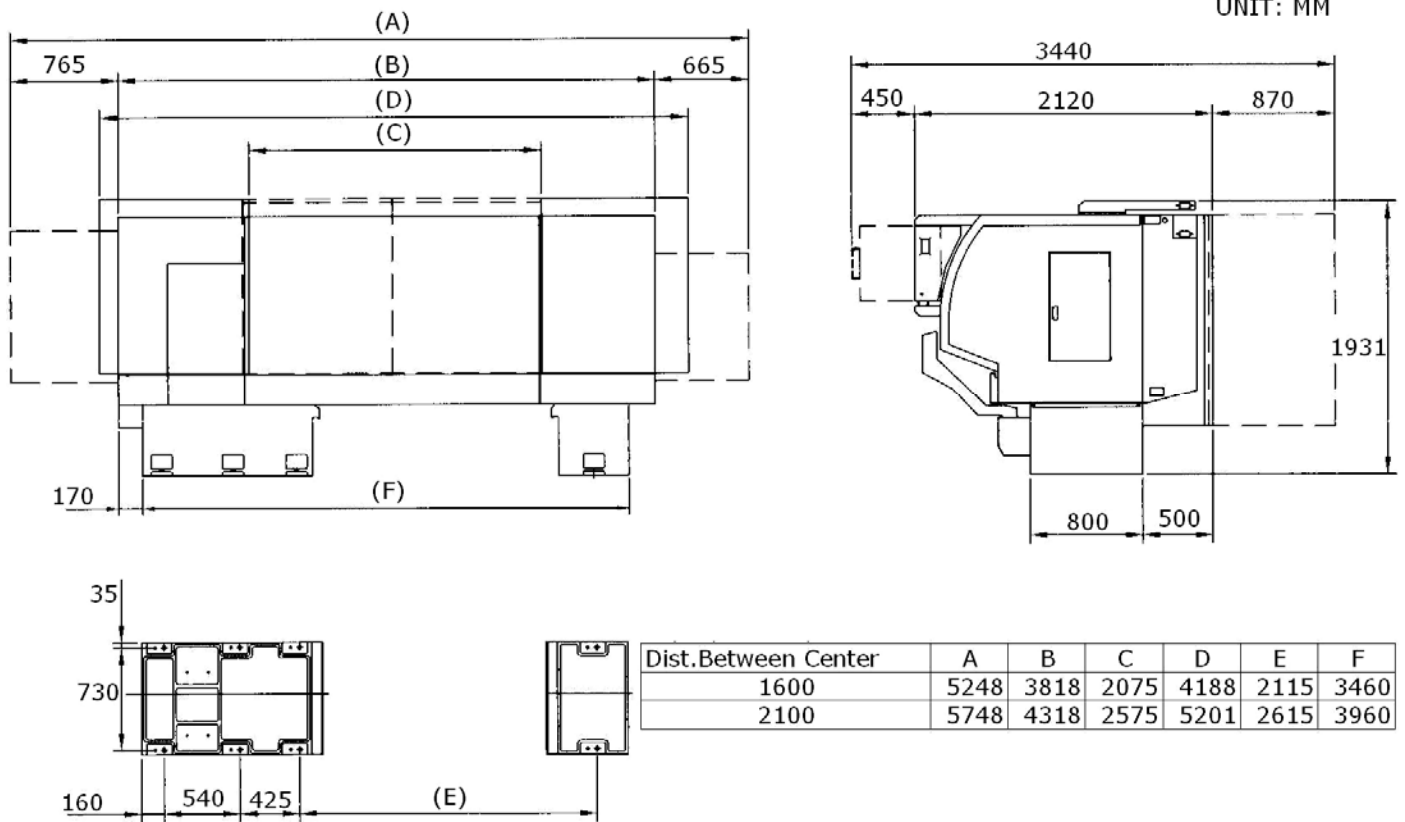

26/30/32 - 120

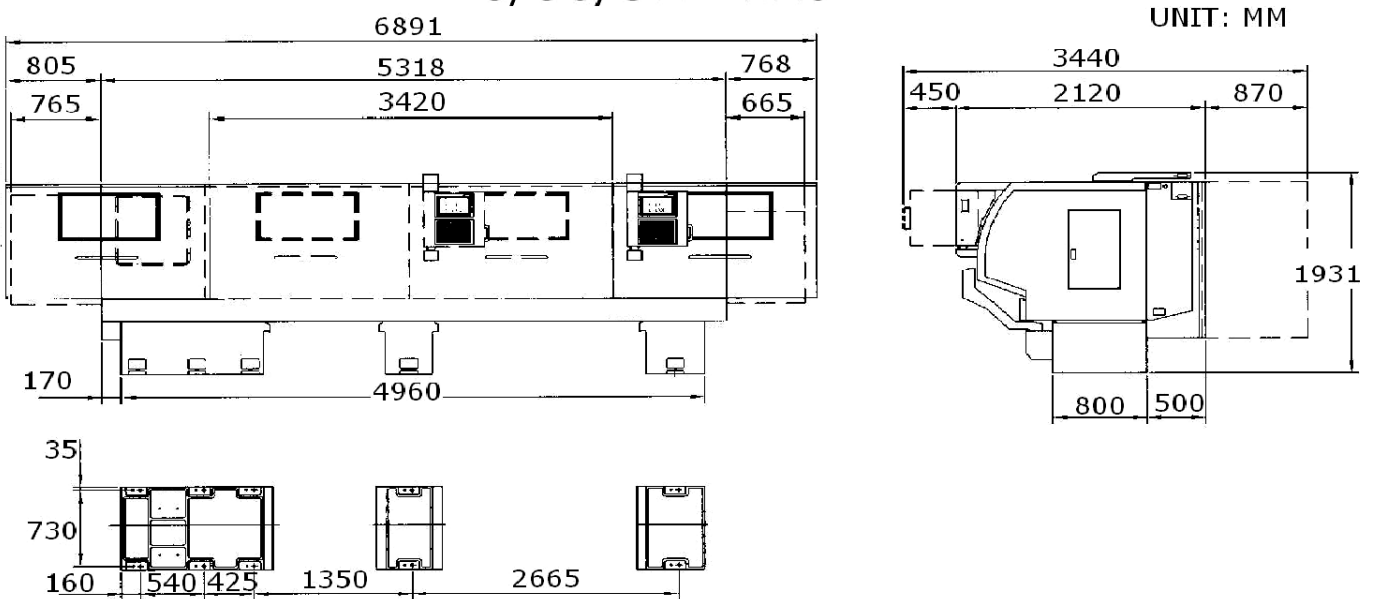

Dimensional drawing

26/30/32 - 160

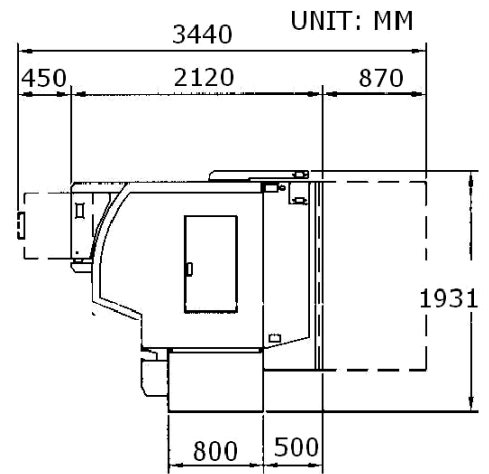
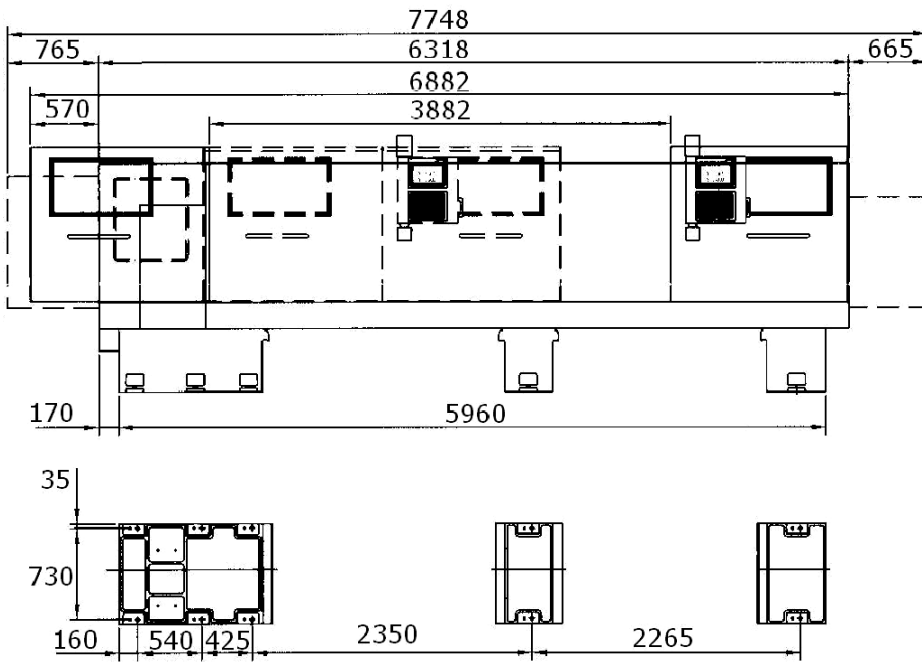

26/30/32 - 200

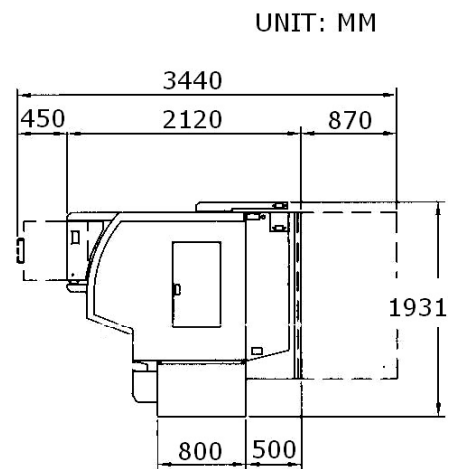
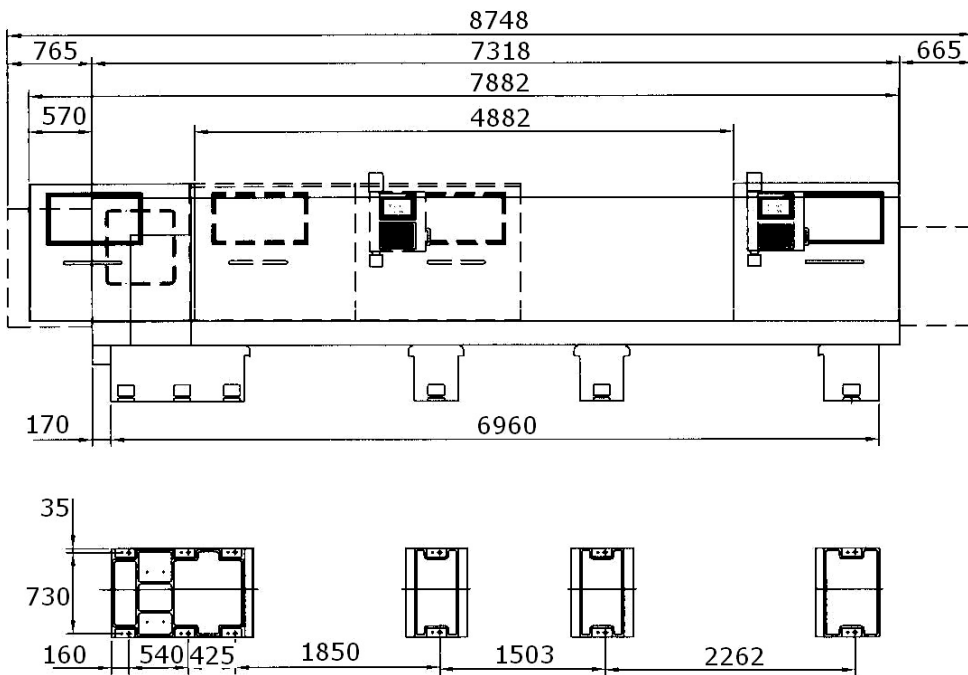

4.3.1 Interrupted diagram of tool rack

Unit : mm

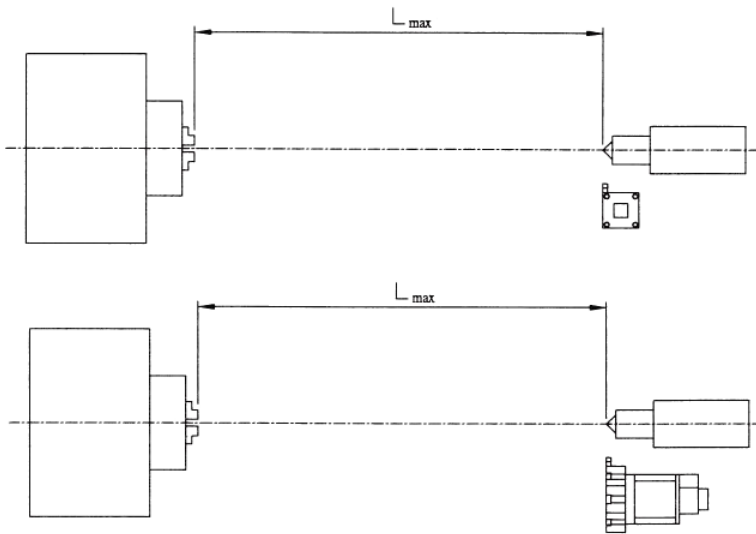

TURRET	MODEL	L max.
4 WAY Toolpost	KL-3060	1400
	KL-3080	1900
	KL-30120	2900
	KL-30160	3900
	KL-30200	4900
8 Station Turret	KL-3060	1250
	KL-3080	1750
	KL-30120	2750
	KL-30160	3750
	KL-30200	4750

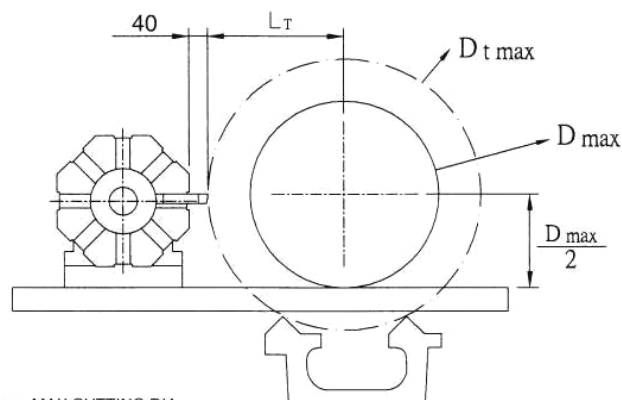
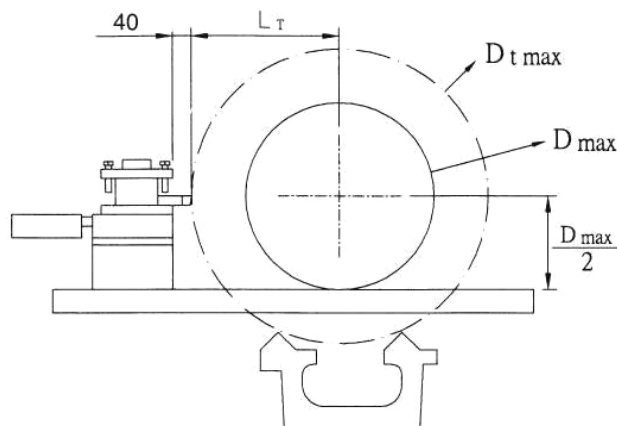

D_{t max}=MAX CUTTING DIA.
D_{max}=MAX DIA. OF WORKPIECE
L_T=MAX CUTTING LENGTH

TURRET	MODEL	D max.	Dt max.	LT
4 WAY Toolpost	KL-3000	Dia.500 mm	Dia.770 mm	385 mm
8 Station Turret	KL-3000	Dia.500 mm	Dia.690 mm	345 mm

Standard Working Capacity for KL-3000 and 3200 Series

KL-3000 Series with LS-200/8-Station Turret

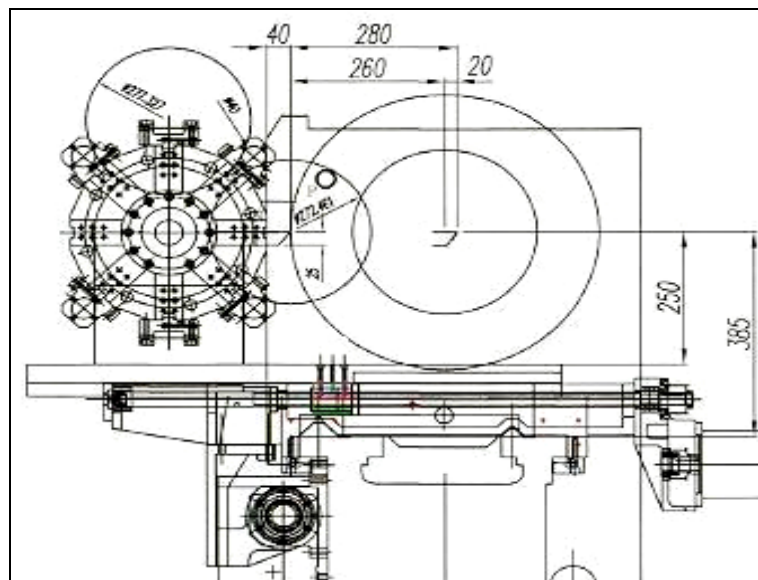

KL-3200 Series with LS-200/8-Station Turret

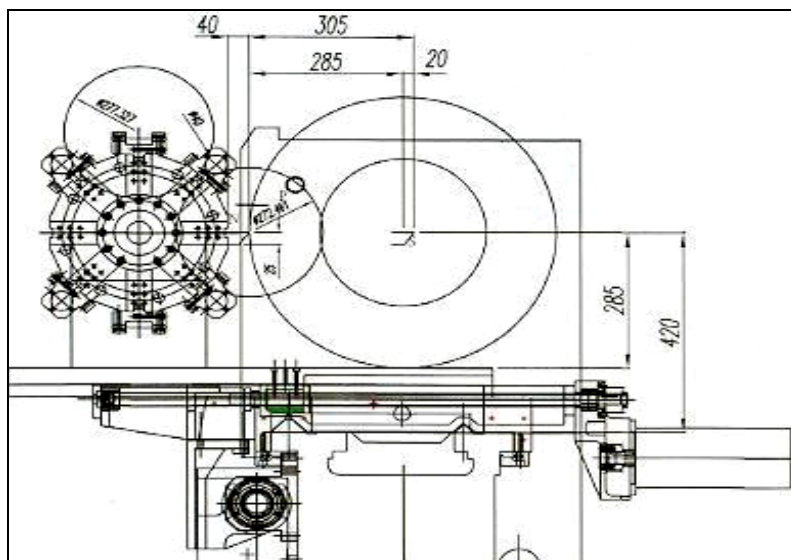

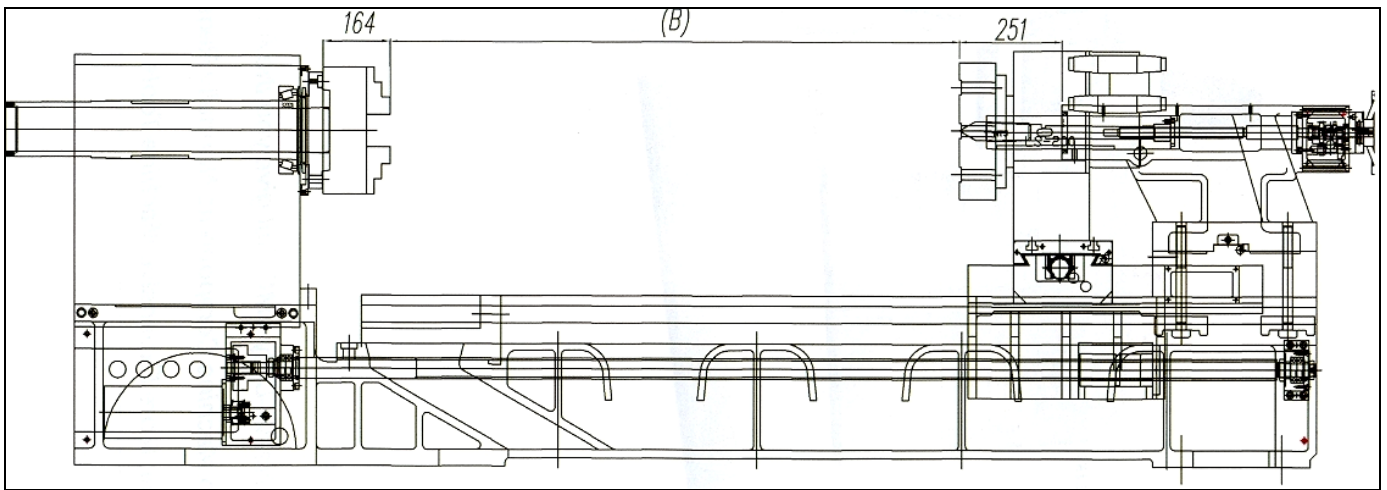

MODEL	(B): Z-AXES STROKE
KL-3260 / KL-3060/KL-2660	1250 mm
KL-3280 / KL-30120/KL-2680	1750 mm
KL-32120 / KL-30120/KL-26120	2750 mm
KL-32160 / KL-30160/KL-26160	3750 mm

4.4 Unpacking

Remove the first top cover of wooden case and then the plates on four sides. Carefully take out fittings at first, if necessary. Remove the set screws used for holding the machine in the base.

Cautions:

- (1) Be careful of the nails and burrs on the dismantled plates.
- (2) Wear gloves while dismantling the case.

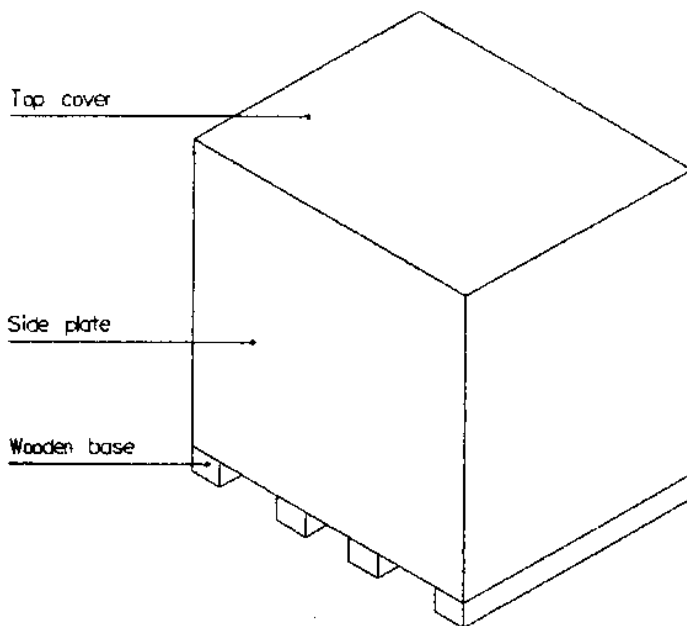

Figure 6

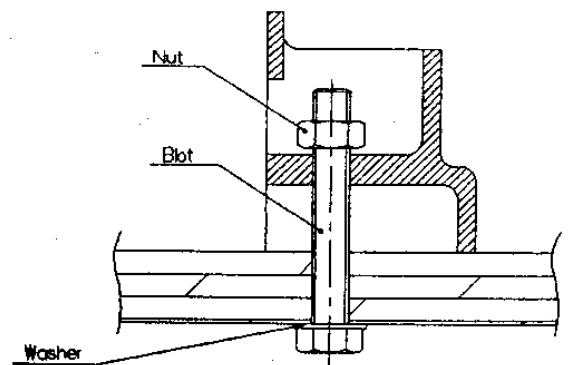

Figure 7

4.5 Carriage

4.5.1 Lifting

Use following equipment to lift the machine.

UNITS: Kgs

MODEL	Weight
KL-3060, KL-3360	5000
KL-3080, KL-3380	5500
KL-30120, KL-33120	6300
KL-30160, KL-33160	7000

- Crane : 8 tons capacity
- Wire cable : $\varnothing 16\text{mm}$ X 2000mm X 4
- Sling bolt : 4 pcs

First fasten the sling bolts on the machine base then set the wire cable on the sling bolts and the hook.

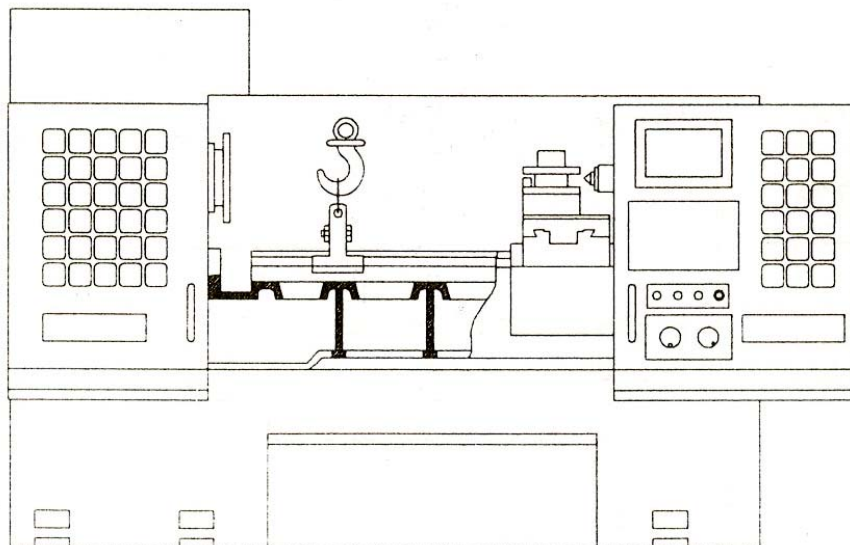
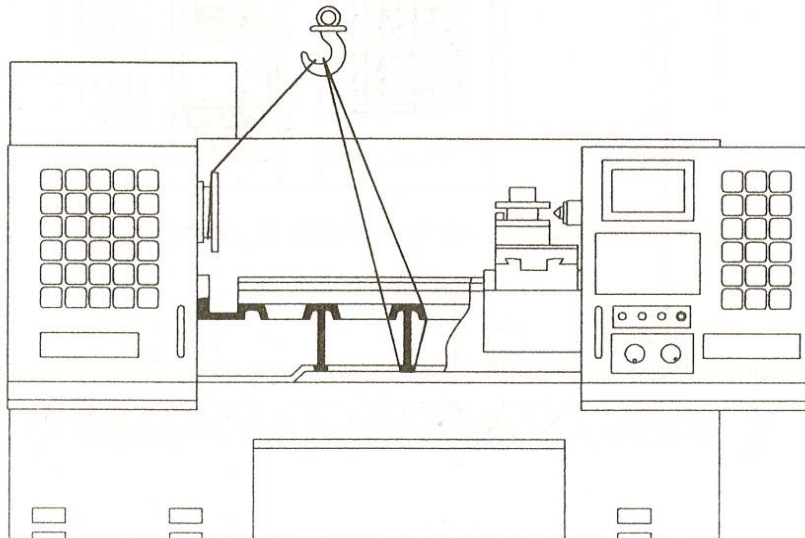

Caution for lifting:

- (1) Lift the machine with the slowest speed of crane.
- (2) Maintain machine balance during lifting. Lay down the machine carefully and slowing to the desired location to prevent effect in precision.
- (3) Protect the machine with soft cloth or hard paper board at the places the wire cables may touch.
- (4) Prevent wire cables from contacting the saddle so as not to damage the saddle guide ways.
- (5) During lifting, nobody is allowed to stand beneath machine. Keep persons away from the dangerous range at least two meters.

4.5.2 Carriage by fork lift

Use fork lift with safety load more than 5 tons to transport the machine to the final location in case of lack of a crane. In this event, it is not necessary to remove the base packing plate.

- 1) During carriage by fork lift, lift the machine from back. Be careful and move it slowly while laying down the machine to avoid bad effects on mechanical precision.

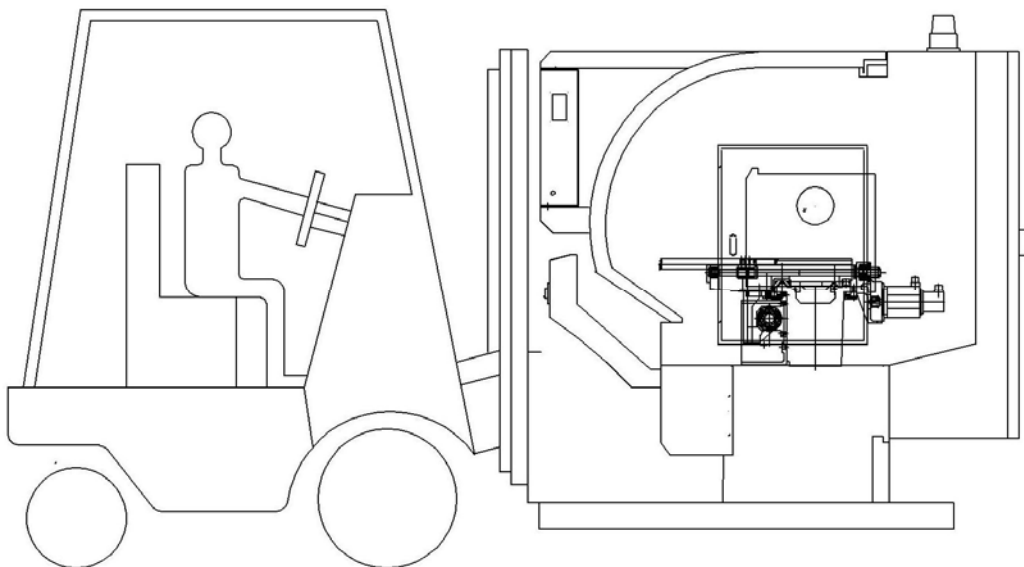

CAUTIONS:

- (1) During carriage, always keep balance of gravity center to prevent machine from tilting.
- (2) In case of using fork lift, let the gravity center of machine tilt backwards.
- (3) Fork lift should be operated by a qualified person.

4.5.3 Lay down the machine

Before laying down the machine, fix the adjusting screws on the base, make the machine as close as possible to the floor, and position the leveling pads in place so as to increase

the stability of machine. In the event of transporting a machine by fork lift or rollers, remove the set screws which secure machine on wooden base before laying down the machine.

4.6 Clean the machine

All protective coating must be removed before using the machine. Do not attempt to move any ways if the coating still exists.

Be cautious while selecting a suitable cleaning agent. Paraffin applied with a clean brush will soften the protective coating. The protective coating can then be removed with clean rags.

- NOTE:**
1. Do not use gasoline or any other flammable solution to clean the machine, just use kerosene or diesel .
 2. Clean and lubricate all the expose ways of table and saddle. Drive the table & saddle to one end of travel.. Clean and lubricate ways throughly then drive table & saddle to the other end clean and lubricate ways throughly as well. Be sure to use a suitable lubricant such as Sunoco Waylube #11180 or Mobil Vactra Oil #2.

4.7 Leveling of the machine

It is of the greatest importance that the lathe be level . If it is not, the lathe bed will be twisted, throwing the lathe out of accurate. It is impossible to do accurate work on a lathe that is no level. A lathe bed that is not level will in time acquire a permanent warp, damaging it beyond repair. Please prepare the following tools to adjust machine leveling:

1. Accurate spirit leveling gauge (spec. 0.02 mm/1000mm or 0.001 in/4ft)
2. Two adjustable wrench

Clean the table surface throughly, set one of the spirit leveling gauges on the longitudinal direction and the other on the cross direction of the slide. If there is only one leveling gauge available, then use it on both directions alternately.

Adjust the six leveling screw bolts 1 located at the bottom of the machine base (as shown in Figure 3-3) until the machine is leveled within 0.02 mm/ 1000mm (“ *0.001 ” / 4ft) in both directions.

Look the nuts 2 on the leveling screws, and recheck the level to see whether the level of Machine is still correct.

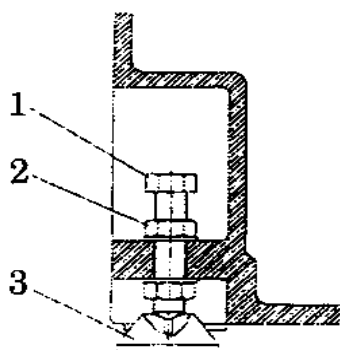
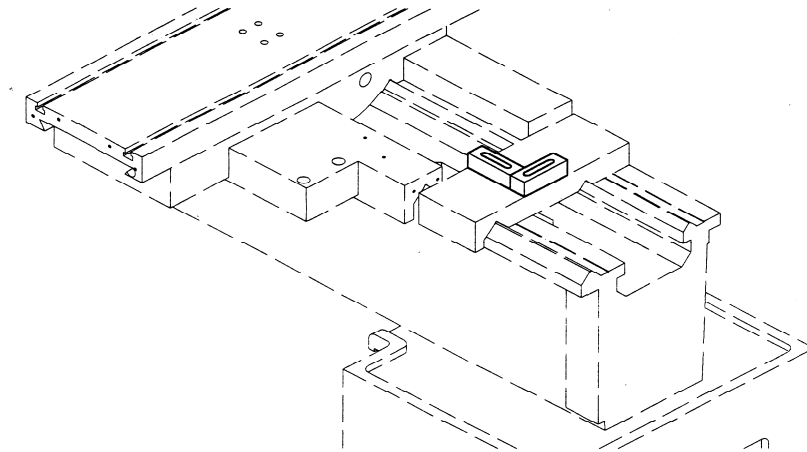

Fig 8

Recommendation: For the newly installed machine, check its level once every week. When the foundation is rigid enough, then you may level the machine once per month.



4.8 Placement of hydraulic system for Turret or hydraulic chuck. (Optional)

Connect the circuit of hydraulic motor to the electric box.

Note: About weight of the hydraulic tank, with full oil refer as following. Be careful of lifting.

4.8.1 Fill hydraulic oil (optional)

In order to ensure trouble-free operation. Hydraulic system should be supplied with correct oil.

Please refer to the following for the qualified oil information.

BRAND	OIL MODEL
SHELL	TELLUS 32
ESSO	NUTO H 32
MOBIL	VALCUOLINE 1405
MOBIL	D.T.E Light 4

Capacity of the hydraulic oil tank is **60 liters**. Fill the oil through the oil inlet on the tank and examine the oil level come to the middle point of the meter.

- Note: 1. Do not switch on hydraulic pump motor before hydraulic oil is filled.
 2. Do not adjust it in normal condition.

***** Pressure setting for hydraulic system *****

Standard pressure:

- Main pressure..... 35kg/cm²
- Chuck18~25kg/cm²
- Tail stuck 5kg/cm²

Note: 1.The chuck pressure adjustment according to the speed of spindle.

- 3.Reducing pressure for inter-hole workpiece.
- 4.Increasing pressure for clamping by no-step jaws.
- 5.Do not setting pressure of tail stock too high in case of damage the spindle bearings.

Chuck pressure – Spindle speed reference data	
Chuck pressure kg/cm ²	Spindle speed R.P.M.
18 ~ 24	50 ~ 2000
20 ~ 25	2000 ~ 2500

COOLANT SYSTEM

- (1) The coolant system is usually located at the left side of the machine.
- (2) Please add uniformly mixing coolant to tank. First add 1/3 water into the tank, pour in the soluble coolant then fill water to the top level of the tank and stir it well. We suggest the mixing ratio for normal surface grinding is 1/60 to 1/80.
- (3) Push the button **Coolant** on the control panel to start the coolant pump motor. Adjust the throttle valve to control the coolant flow rate.

Note: 1. When start the coolant pump, please check the rotation direction of pump with the direction indicated by an arrow.

2. Do not start the coolant pump except the tank has been filled with coolant.

4.11 LUBRICATION

The ability, reliability, and endurance of the machine rely on excellent lubrication management system. Ensure that the surfaces where relative motion occurs are well lubricated, and check the lubricant oil regularly. Keep sufficient levels of lubricant available or replace the new lubricant if necessary. One can maintain a longer life cycle for the machine.

NOTE:

Using improper lubricants will lead to poor performance and malfunction of the machine. Keep the lubricant, especially on the headstock, in a clean condition at all time, this will ensure that lubrication function properly.

4.11.1 Centralized Lubrication System

This system (shown as figure 9) adopts automatic intermittent lubricant supply which includes metering valves for proportional distribution and includes an alarm for low fluid level warning. Still, please check the fluid level before operation.

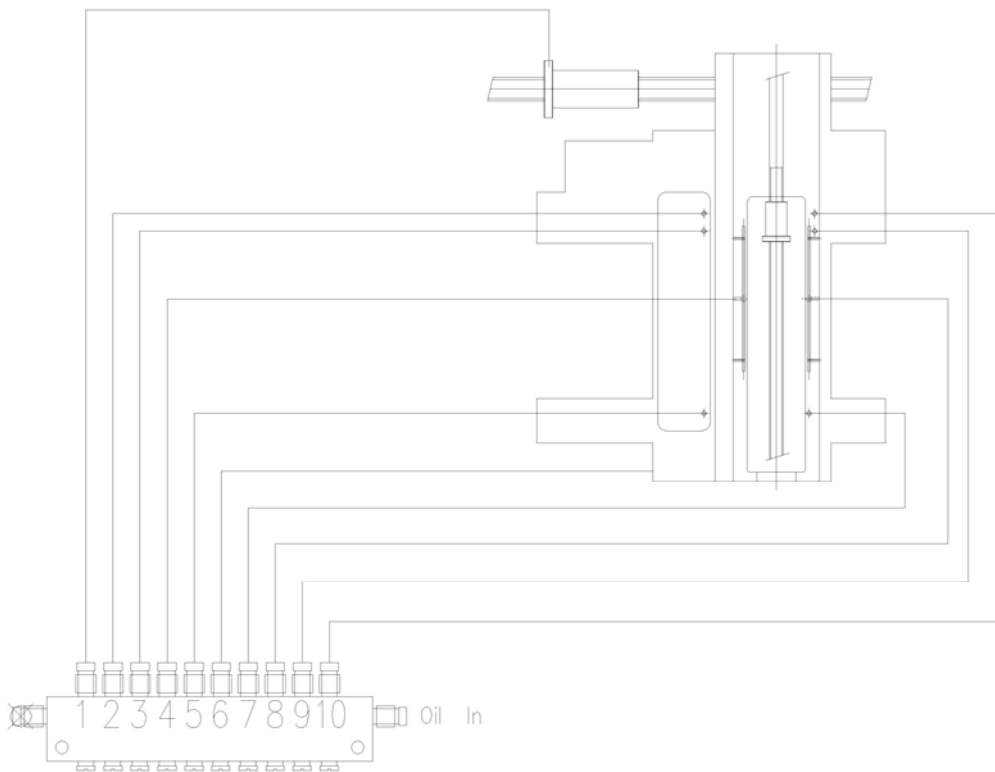

Oil Guide Table

ITEM \ BRAND	MOBIL	SHELL	ESSO	EXCHANGE
LUBRICATOR OF PNEUMATIC	DTE LIGHT	TURBO T32	TERESSO 32 NUTO H32	LEVEL CHECK WEEKLY
AUTO LUBRICATOR SYSTEM	VACTRA 2	TONNA T68	FEBIS K68	LEVEL CHECK WEEKLY
HEADSTOCK	DTE LIGHT	VITREA 27	TELLESSO 43	TWICE A YEAR
HYDRAULIC SYSTEM	DTE 24	TELLUS 32	UNIVIS N32	ONCE A YEAR

4.11.2 Others

There are three oil balls on the tailstock.

Please add 3 drops of recommended lubricant to them respectively every day before operating to ensure the smoothness of operation. (Shown as figure 10)

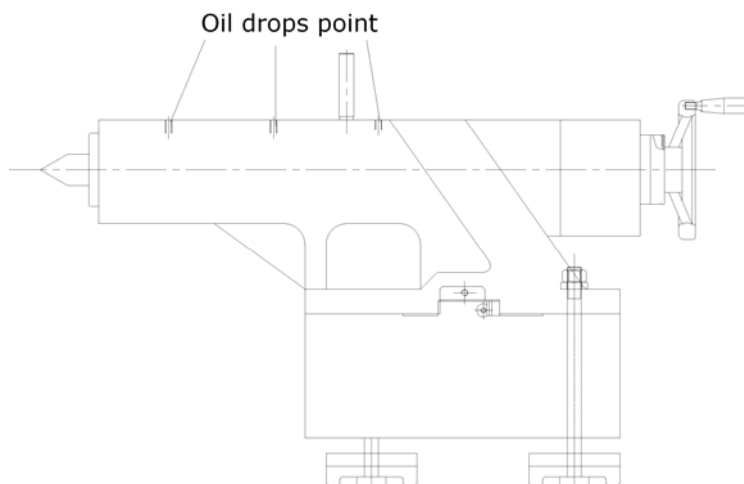

Figure 10

4.11.3 Lubrication for headstock

Check all the fittings of lubrication system under normal operation temperature if oil leaking is found, tighten the fitting. Inspect oil level daily.

4.12 Fittings

Check all fittings after 50 hours of operation especially their tightness between tubes, After that, do the regular check every 200 hours.

4.13 Machine Body

In order to maximize the machine performance, the accuracy of headstock and all slides have to be re-adjust after three months of operation. After that, re-adjust every six months to one year to keep the machine in best accuracy.

4.13.1 Headstock

Aligning Headstock:

If taper appears on turned workpiece, on when facing, adjust the parallel of headstock by the following steps. (Shown as figure 11)

1. Insert gauge bar in the spindle bore, attach the base of test indicator to the toolpost. Apply the stylus of the indicator to the outer diameter of the bar. Move the saddle along Z-axis and measure the maximal difference
2. If the pointer of the indicator swings drastical, release the headstock fixing screws and adjust the adjusting screws to find the parallel of spindle and Z-axis
3. After adjustment, tighten the fixing screws and move the saddle to observe the pointer of the indicator.

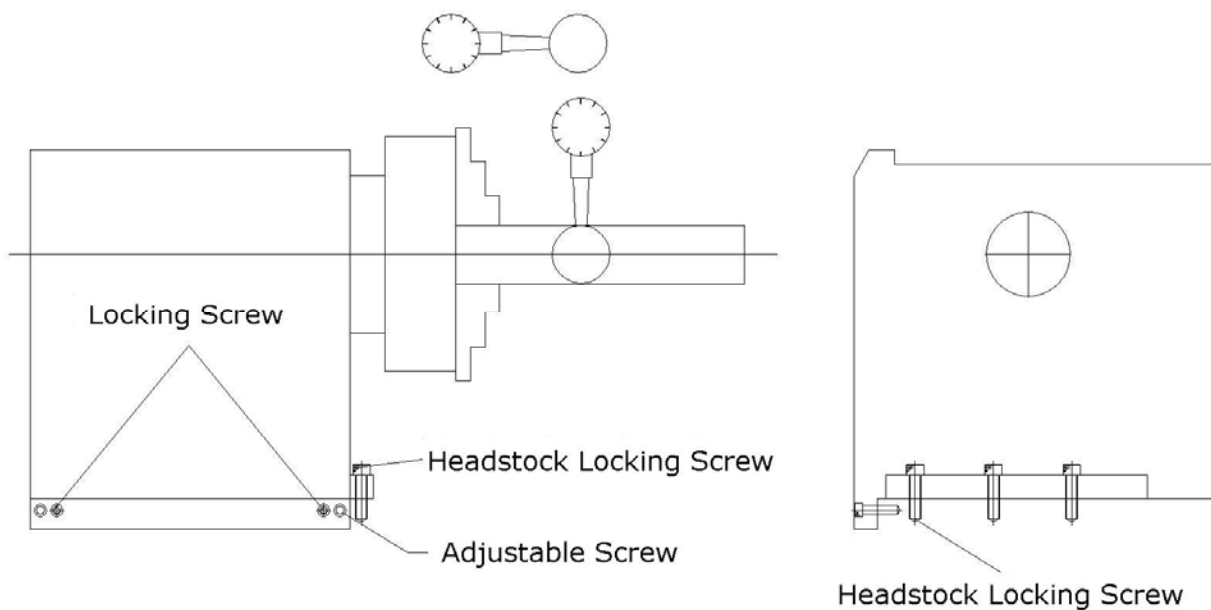

4.13.2 CHUCKS AND CHUCK MOUNTING

WARNING: USE ONLY HIGH SPEED CHUCKS WITH THESE MACHINES.

When fitting chucks or faceplates, first, ensure spindle and chuck tapers are specially clean and that all cams lock in the correct positions: see Fig shown, It may be necessary when mounting a new chuck to re-set the cam-lock studs (A). To do this, remove the cap-head locking screws (B) and set each stud so that the scribed ring (C)

Is flush with the rear face of the chuck-with tile slot lining up with the locking screw hole see Fig shown.

Now, mount the chuck or faceplate on the spindle nose and tighten the six cams in turn when fully tightened, the cam lock line on each cam should be between the two V mark on the spindle nose.

If any of tile cams do nut tighten fully within these limit marks, remove the chunk or faceplate and re-adjust the stud as indicated in the illustration. Fit and tighten the locking screw (B) at each stud before remounting the chuck for work.

A reference mark should be made on each correctly fitted chuck or faceplate to coincide with the reference mark scribed on the spindle nose.

This will assist subsequent remounting. Do NOT INTERCHANGE CHUCKSOR FACEPLATES BETWEEN LATHES WITHOUT CHECKING FOR CURRENT CAM LOCKING.

IMORTANT: Be careful not of speed limitations when using faceplates; “21 in faceplate should not be at speeds greater than 625 rev/min. and 14” in faceplates at not more than 840rev/min.

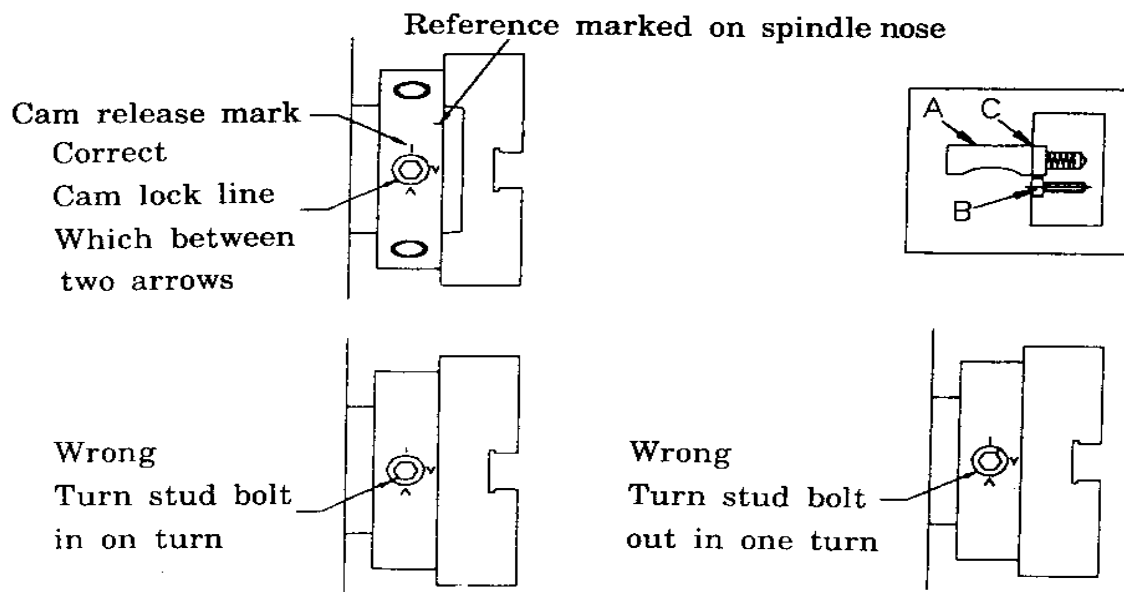

4.13.3 Cross-Slide

If the gibs between slide and saddle become loose, it will affect the machining accuracy. You should regularly check and adjust them every six months according to the following steps.

1. Release the screw 1
2. Remove slide cover 2 as shown as Figure shown, then the gibs can be seen.
3. Use flat head screw driver to release the adjusting screw 3 about 1/2 turn CCW.
4. Tighten screw 4 about 1/2 turn CW.

5. Move the slide back and forward to satisfied smoothness.
6. Reassemble the cover 2.

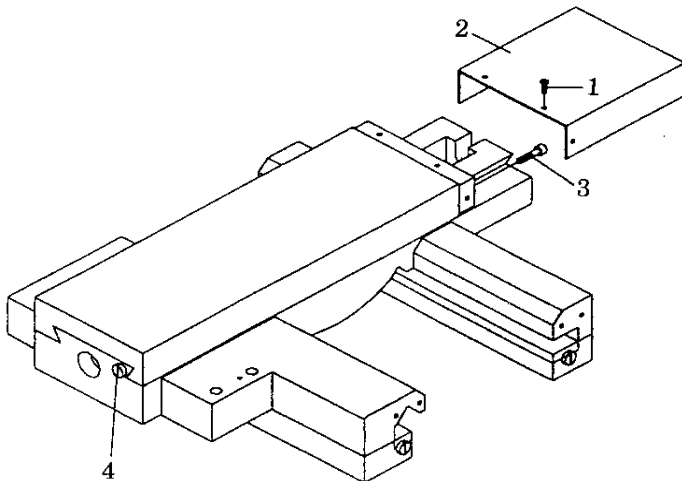

4.13.4 Saddle

If the gibs between saddle and bed become loose, it will affect the accuracy of saddle travel. Check and adjust them every six months according to following steps.

1. Use Flat head screw driver to loosen the adjusting screws 1 & 2 as shown as Fig. about 1/2 turn CCW.
2. Appropriately tighten adjusting screws 3 & 4 as shown in figure3-12 about 1/2 turn.
3. Move saddle left and right to a satisfied smoothness.

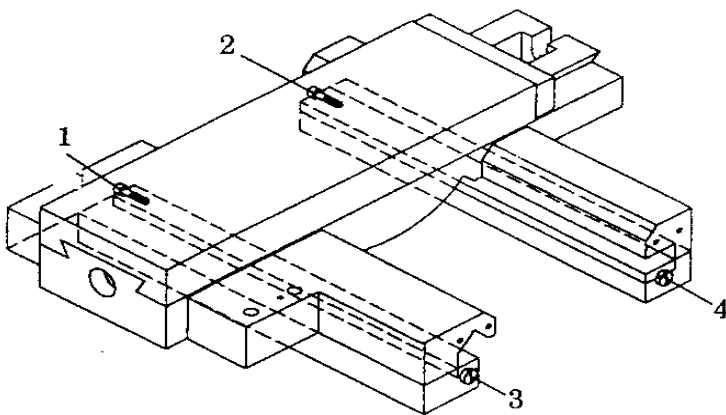

4.13.5 Load & Unload Center of Tailstock

To unload the center just hold the center and back off the tail spindle. Please wipe the taper part of the center clean before loading it to the tail spindle.

4.13.6 Aligning Tailstock to Spindle

When you found the tailstock precision is not accurate, the adjusting ways are as follow:

- (1) If it incline the back: The shape of work piece like Fig. in this condition, release clamp lever

1

and also release hexagon screw 2, then loose the set screw 3 at front and tighten the set

screw at the back to take it toward front.

(2) If it incline the front: The shape of work piece like Fig in this condition, release clamp lever 1 and also release hexagon screw 2 at the front to take it toward the back.

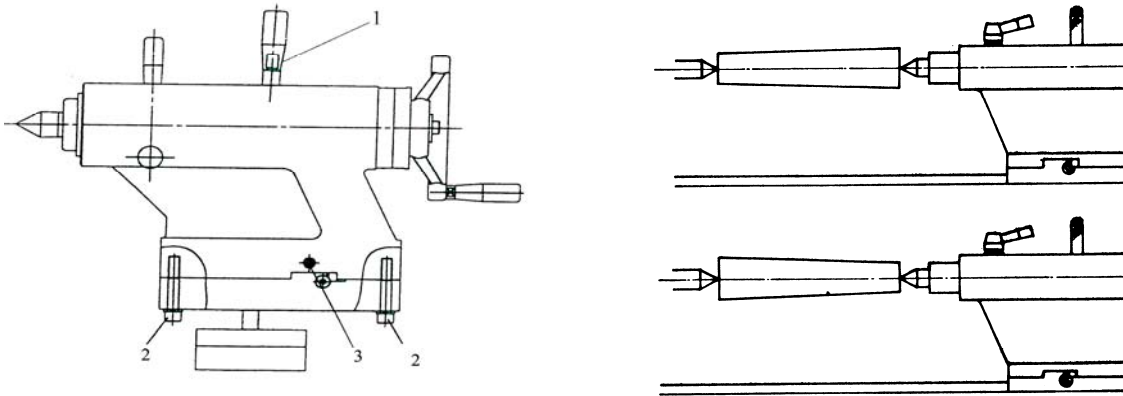

4.13.7 Adjusting Belt Tension

The main spindle torque depends on the motor power transmitted through the belt, The operator must check the V-belt's tension frequently and adjust screw if it becomes loosened.

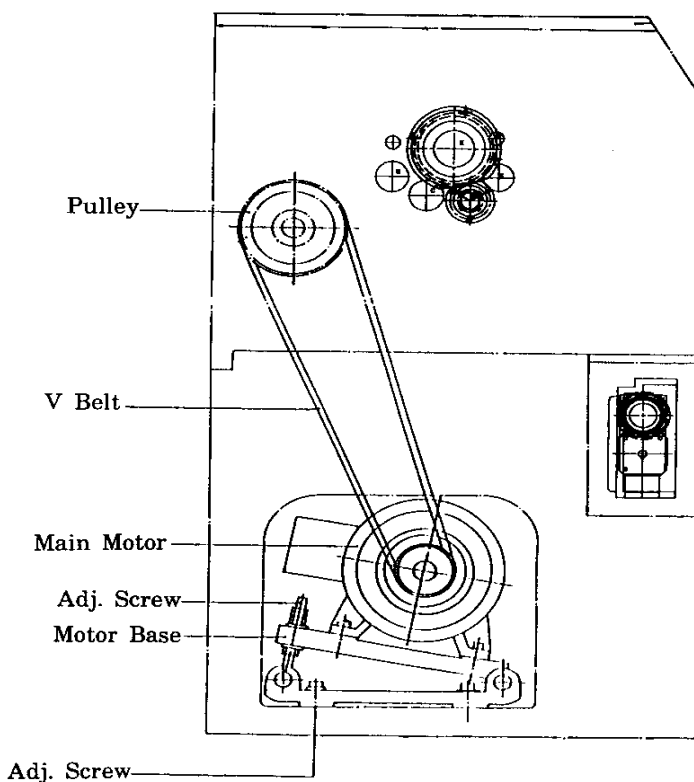

4.14 Electric Equipment

4.14.1 Motor

Spindle motor is equipped with IP. Therefore, no special care is required to check and clean it

every six months. Other motors should be checked annually.

Spindle bearing is greased before shipping. Grease amount is able to support 8-10 hours of daily operation up to two years. Still, it is recommended to check it annually by a qualified technician.

4.14.2 Control Units

No special care required. Clean CRT and Key Board by using a none detergent soap.

4.14.3 Wire connectors

Check them annually, and tighten them if necessary.