

OPERATING MANUAL

HEALTH AND SAFETY GUIDANCE NOTES MODEL: B8FC



DATE: 2002/07/03
VERSION: 1.3

1. Safety regulations	1-1
1.1 General safety rules	1-1
1.1.1 Operating safety precautions	1-1
1.1.2 Safety for tool use	1-2
1.1.3 Machine operator's precautions	1-2
1.1.4 Environmental safety	1-3
1.2 Danger areas of machine	1-4
1.3 All safety related elements	1-5
1.4 Warning label's, contents and locations	1-6
2. Description of the machine	2-1
2.1 General description	2-1
2.2 Out looking, main units, and operator's position	2-1
2.2.1 Names of machine parts	2-1
2.2.3 Noise level	2-4
2.2.4 Spindle nose detail	2-4
2.3 Machine specifications	2-5
2.3.1 Specification	2-5
2.3.2 Constraints on materials	2-5
2.3.4 Requirements of operators and servicemen	2-7
2.3.5 Requirements of circumstance	2-7
3. Preparation for installation	3-1
3.1 Requirements of foundation	3-1
3.2 Requirements of power supply	3-2
4. Transportation and installation	4-1
4.1 Shipping chest	4-1
4.2 Notices for transportation	4-1
4.3 Notices for open the shipping chest	4-2
4.4 Requirements of transportation equipment	4-2
4.4.1 Methods of transport	4-2
4.4.2 Cautions for unpacking	4-4
4.5 Notices for installation	4-4
4.5.1 Work environment	4-4

4.5.2 Power supply installation	4-4
4.5.3 Leveling adjustment	4-5
5. Preparation for trail runs	5-1
5.1 Cleaning	5-1
5.2 Visible inspection	5-1
5.3 Fluids	5-1
5.4 Electrical earthing system	5-1
6. INSTRUCTIONS IN OPERATIONS	6-1
6.1 Head stock	6-1
6.1.1 Manual feed	6-1
6.1.2 Manual micro motion feed	6-1
6.1.3 (Automatic feed)	6-1
6.1.4 Headstock cross tilting	6-2
6.1.5 Speed change of spindle	6-3
7. Lubrication & coolant	7-1
7.1 Headstock lubrication	7-1
7.2 Spindle	7-2
7.3 Lubrication tank and drawing	7-2
7.4 Coolant replacement	7-3
8. Adjustment	8-1
8.1 Adjustment of work table gibs	8-1
8.2 Adjustment of saddle gib	8-1
8.3 Adjustment of elevating gib	8-2
9. Service and maintenance	9-1
9.1 Belt maintenance	9-1
9.2 Lubricant system maintenance	9-1
9.3 Cutting coolant system maintenance	9-1
9.4 Electricity maintenance	9-1
9.5 Maintenance measures for critical safety devices	9-2

9.6 Cleaning for chip	9-2
10. Self service and dismantling	10-1
10.1 Main tenance precaution	10-1
10.2 Safety confirmation	10-1
10.3 Requirements of replacement	10-1
10.4 Dismantling of motor cas showing	10-1
10.5 Replacement of speed change belt (l)	10-2
10.6 Replacement of HI-LO speed change belt (n)	10-3
10.7 Inspection and maintenance period list	10-4
10.7.1 Inspection	10-4
10.7.2 Maintenance	10-4
11. Troubles and trouble shooting	11-1
11.1 X-axis, Y-axis and Z-axis	11-1
11.2 Coolant system	11-1
11.3 Lubricant system	11-1
11.4 Electricity	11-1
12.Parts list	12-1
12.1 Head stock upside (1) drawing	12-1
12.2 Head stock upside (2) drawing	12-3
12.3 Head stock infrastructure (1) drawing	12-5
12.4 Head stock infrastructure (2) drawing	12-7
12.5 Head stock infrastructure (3) drawing	12-9
12.6 Head stock infrastructure (4) drawing	12-11
12.7 Column, base assembly drawing	12-13
12.8 Table saddle assembly drawing	12-15
12.9 Table saddle assembly drawing	12-17
12.10 X,Y axis assembly drawing	12-19
12.11 Elevanting assembly drawing	12-21
12.12 Z axis assembly drawing	12-23
12.13 Lubrication, coolant assembly drawing	12-25

1. Safety Regulations

Read this manual thoroughly before using the machine.

1.1 General safety rules

1.1.1 Operating safety precautions

- * The operator must be a technician who is trained in the operation and familiar with the manual.
- * Do study the safety information and practice safety first.
- * The operator should wear safety clothes, such as a helmet safety glass working clothes, safety shoes etc, which must conform to local industrial safety regulations.
- * Eye protection-eye protection facilities must be considered as optional instruments and shall be carefully selected, fitted and used. Compulsory wearing of spectacles with impact resistant lenses shall be a safety policy.
- * Before you start a machine, be sure you know what is going happen.
- * Be sure you know how to stop the machine before you start it.
- * Be alert for any bystanders or unauthorized person who may be in the area of the machine travel limits areas.

An area is not a hazard to the operator that his control station may be hazardous to an assistant or by standers.

- * The operator and person (s) performing maintenance must be mutually aware of each other's presence in the machine area.
- * Do not attempt to perform any cleaning, chip removal or workplace clamping while units are in motion.
- * Do not attempt to measure moving workplaces in the machine, always stop spindle and machine motion when measuring.
- * Do not wear gloves and any hand covering while operating machine.
The operators need wear gloves and safety shoos while leading and unloading.
- * Long hair should be covered with a protective cover such as a hair net.
- * Never take depth of cuts beyond machine's capability.
- * Make sure power has been turned off when machine is unused for sometime.
- * Due to these potential dangers inherent in a machine tool, protective guards, safety design features and warning signs are utilized. For maximum personal safety it is imperative that all operators, maintenance personnel, observers, and all other that could be exposed to inherent machine hazards shall be made fully aware of potential dangers, and are thoroughly instructed in the safety precautions they must follow to avoid those dangers. It is essential that persons required to become involved with the machine are properly trained and have the required knowledge and skill to perform their respective functions.

- * If you are assigned as an assistant for any reason, both the assistant and the operator have the responsibility of deciding whom will be in command of the machine and its controls. Shall only one person controls the machine. Anyone else should stand clearly and be visible to the person who is assigned to operate the machine controls.

1.1.2 Safety for tool use

- * This manual is provided with machine. The user should have the manual available for the personnel working with this machine tool.
- * User must have available adequate lifting facilities capable of lifting within the safe load limits, also appropriate slings and hitches.
- * Do not use broken, chipped or defective tools.
- * Be aware of conditions that may be a fire hazard, such as volatile liquids and machining materials with low fire point.
- * Do not clean a machine with an air hose. Flying chips can cause personal injury or damage to machine.
- * Do not use cutters, wrenches, or other tools that do not fit properly.
- * Do not apply wrenches to moving work or parts.
- * Do not cutting Mg material.

Materials recommend being use for the machine as following:

1. Steel
2. Iron
3. Cast iron
4. Aluminum alloys
5. Capper-bast alloys.

Note: Other materials should be selected carefully by operators.

- * The coolant fluid shall below flash point.

1.1.3 Machine operator's precautions

- * Guards and shields are to be in place at all times.
- * Be sure that all protective guards are in place before the machine is started.
- * During maintenance or lubrication, the machine should be taken out of service.
- * Do not attempt to use the machine beyond its designated capabilities.
- * Always supports the work piece as necessary using chucks, steadies and centers.
- * Never place hand on chuck or work piece to stop rotation of the spindle.
- * Make sure power has been turned off when machine is unused for sometime.

- * Never remove protection for even a short time when operating the machine.
- * Be sure the work piece is mounted securely in the table.
- * Do not attempt to adjust a tool while the machine is running.
- * Do not attempt to brake or slow down moving machine parts with your hands or makeshift devices.

1.1.4 Environmental safety

- * This machine is inadequate for explosive environment.
- * Keep the immediate area tidy. Avoid slippery floors, remove debris, and remove obstacles, remove chips, etc.
- * Remember that your work area may change during the day as material is delivered to and removed from your machine area. Be alert for pinch point and work hazard areas created by workplace storage.

1.2 Danger areas of machine

In general speaking, the specific risks of the machine come from the rotating cutting tool, which is mounted, on the spindle and the motor drives it. However, a table guard is provided and installed on the lower part of the head to reduce the risk.

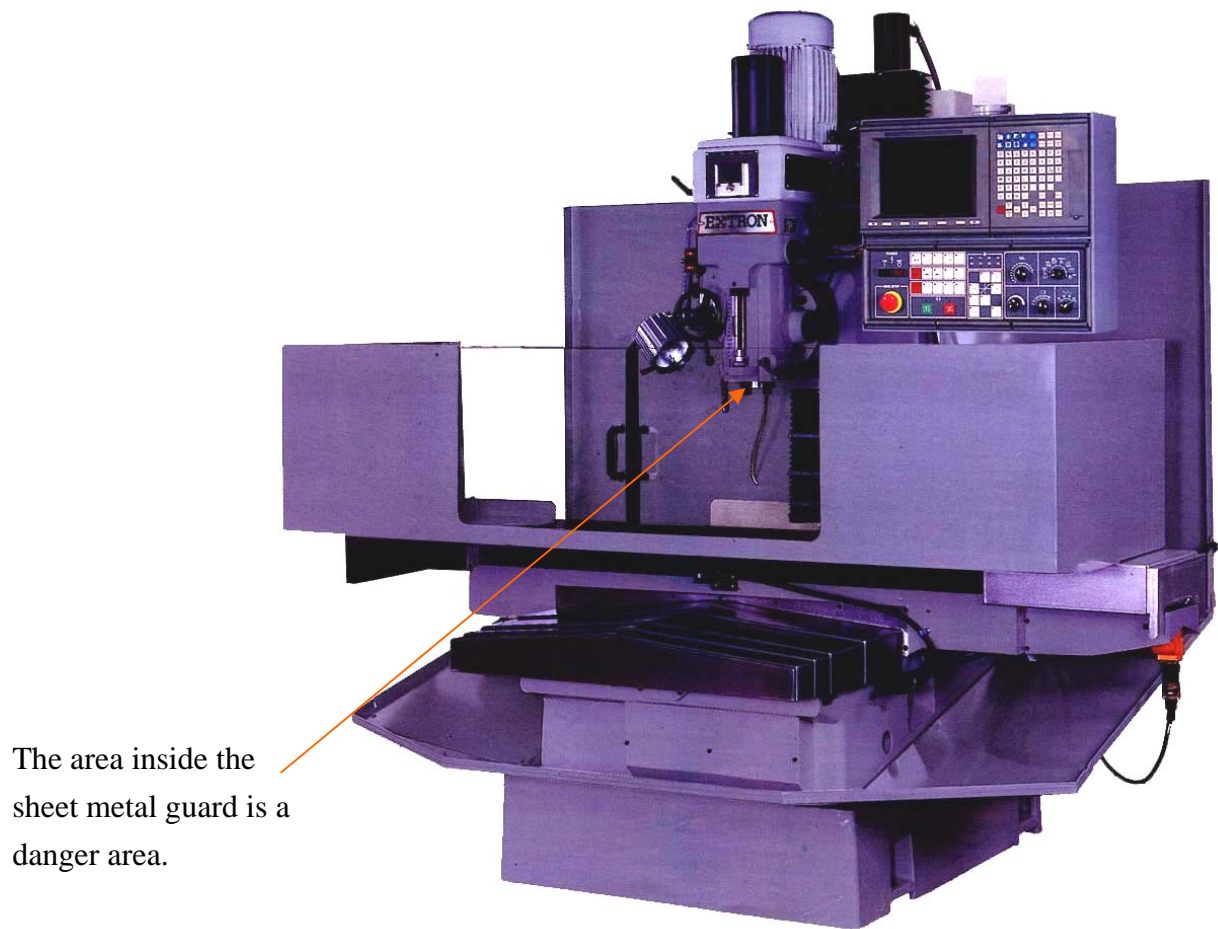
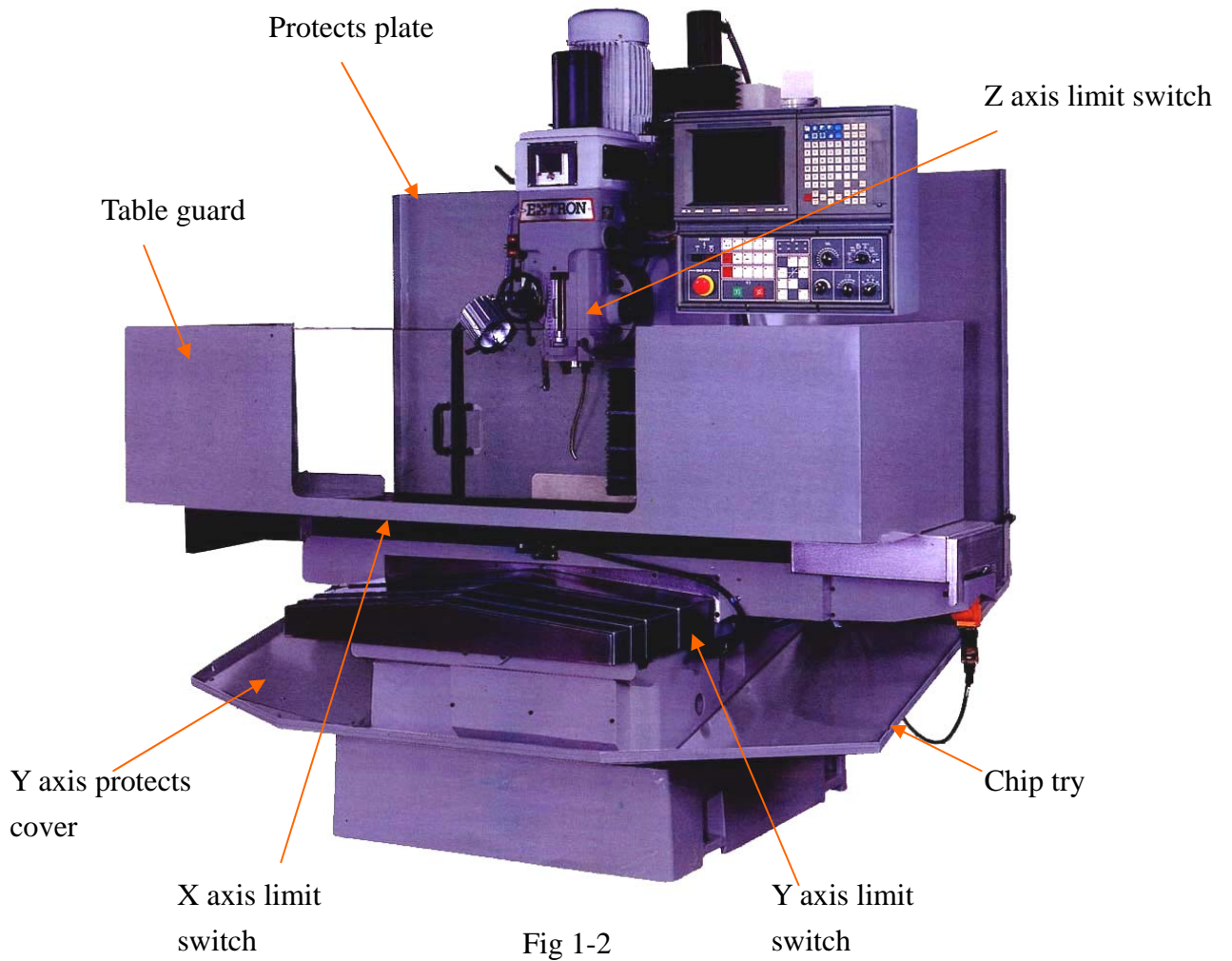

Fig. 1-1

1.3 All safety related elements



1.4 Warning label's, contents and locations

The following pages present all safety related labels attached on this machine as a minimum please read and keep attention on this label before/during operation. They shall be kept in place all time.

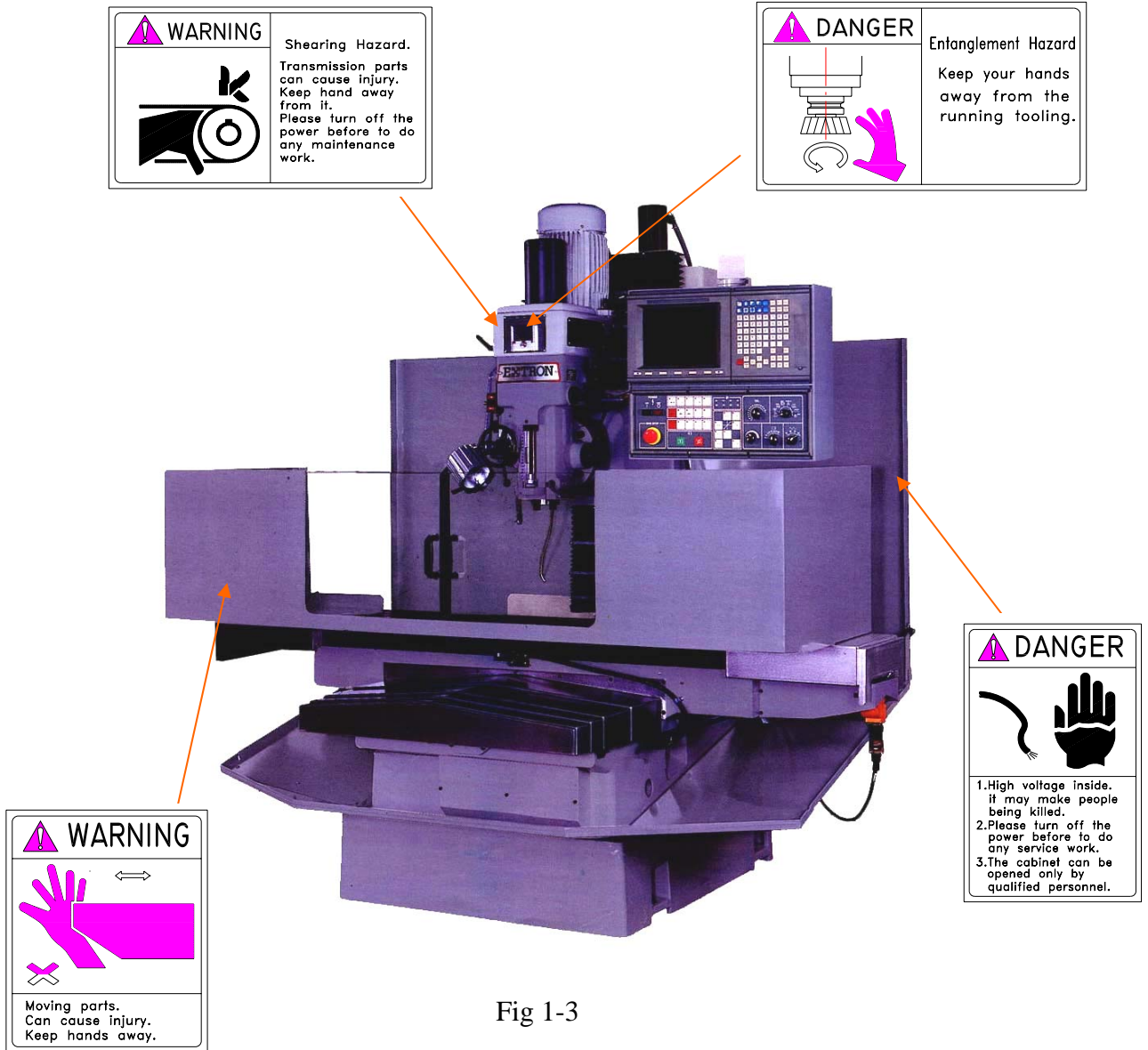

Fig 1-3

2. Description of the machine

2.1 General description

- (1) This machine is designed with theoretical calculation to comply with the stress requirements especially for spindle rigidity, transmission belt strength, X, Y, and Z axes transmission stress, coolant system, lubrication system, and etc.
- (2) Materials used for this machine had been considered for properly corrosion, wearing, and life time to avoid faults on machine.

2.2 Out looking, main units, and operator's position.

2.2.1 Names of machine parts

- (1) Out looking and main units

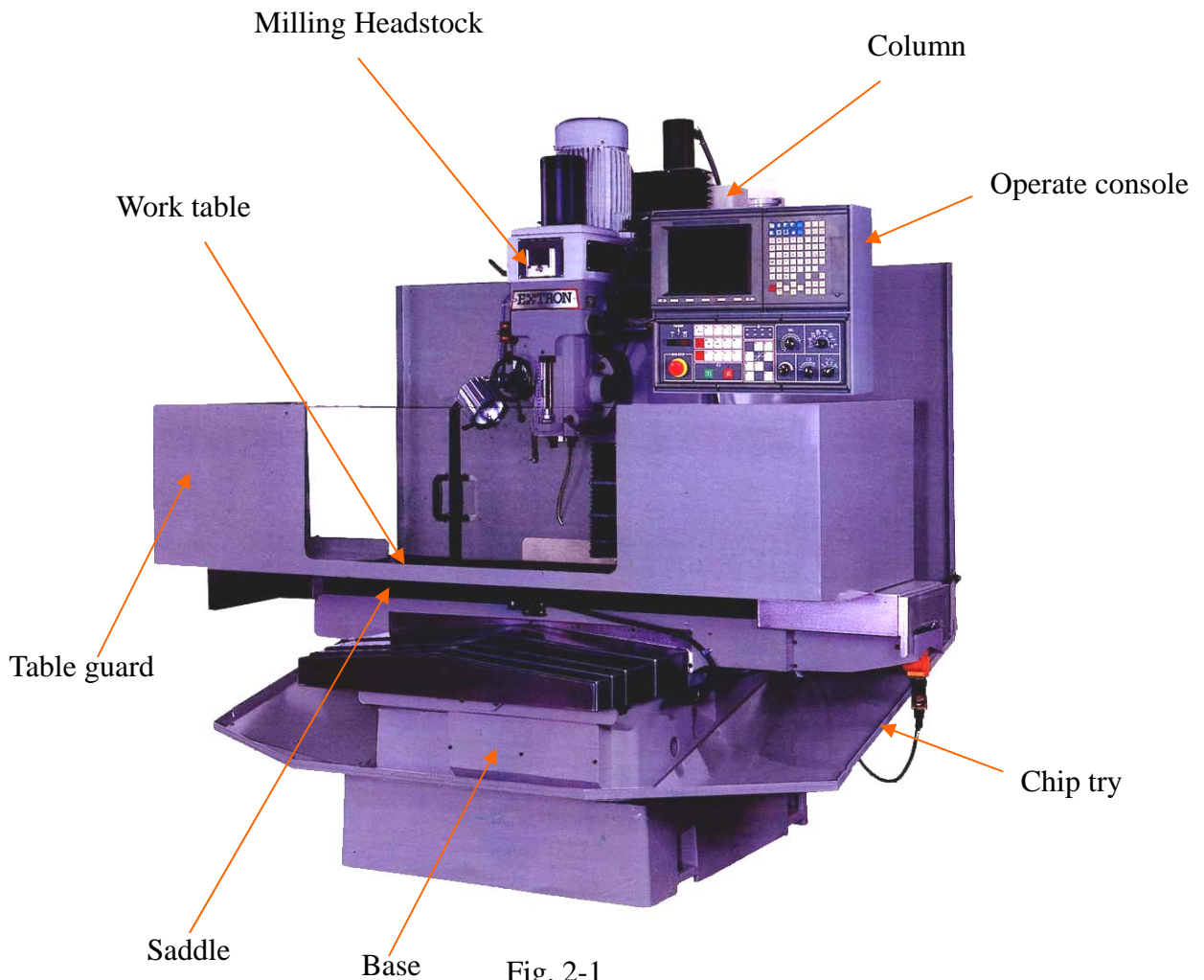

Fig. 2-1

(2) Head stock

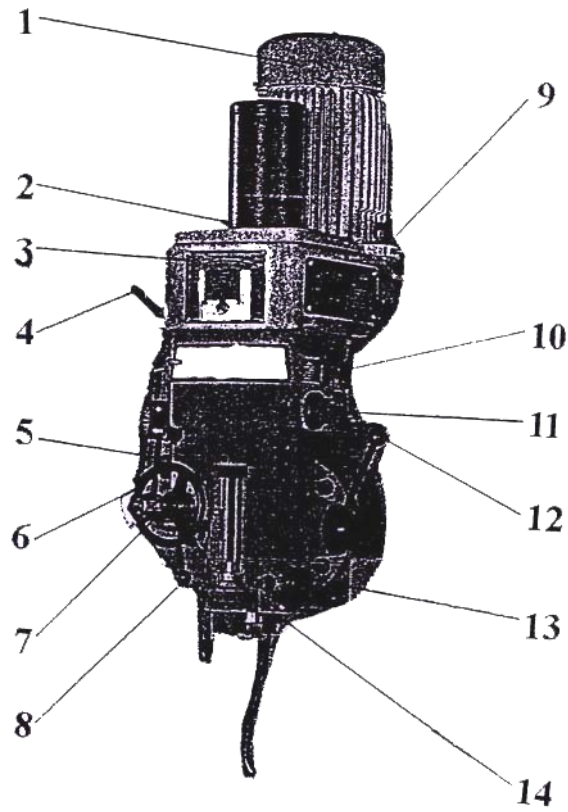

Fig. 2-2

NO.	MAIN UNIT	NO.	MAIN UNIT
1	Spindle motor	8	Feed control lever
2	Motor locking handle	9	Motor locking lever
3	Spindle speed plate	10	Hi-low speed lever
4	Spindle locking handle	11	Change lever
5	Quill feed selector	12	Quill feed lever
6	Handle wheel	13	Quill lock handle
7	Feed reverse knob	14	Micrometer adjusting nut

2.2.3 Noise Level

- (1) The noise test is carried out in compliance with ISO 11202:1996.
- (2) No load
 - a. A-weighted sound pressure level at operator's

$$L_{A,eq} = 73 \text{ dB (A)}$$
 - b. A-weighted sound power level

$$L_{w,eq} = 87.21 \text{ dB (A)}$$
- (3) Load
 - a. A-weighted sound pressure level at operator's

$$L_{A,eq} = 79 \text{ dB (A)}$$
 - b. A-weighted sound power level

$$L_{w,eq} = 91.55 \text{ dB (A)}$$

2.2.4 Spindle nose detail

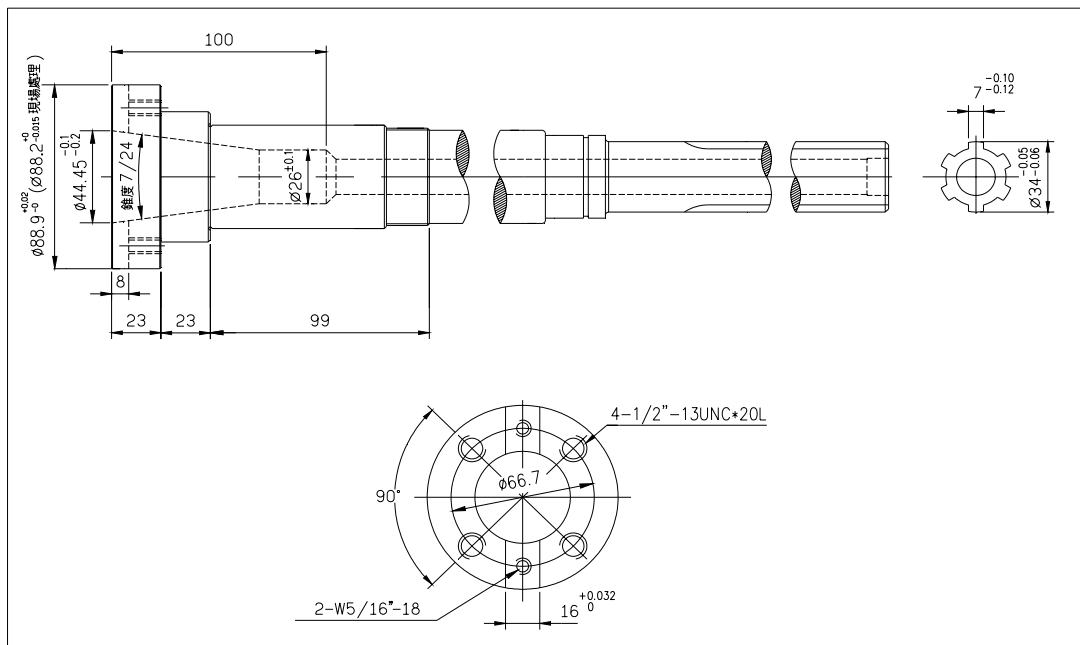

Fig. 2-4

2.3 Machine specifications

2.3.1 Specification

	B8FC
Work table	406x1475mm (16x58")
Table T-slots (WxN)	18mm (0.71")x5
Table load max.	1100kgs (2420 lbs)
X axis travel	1270mm (50")
Y axis travel	560mm (22")
Z axis travel	585mm (23")
Spindle nose to table	85-645mm(3-3/8"-25-3/8")
Spindle nose taper	N.S.T.#40
Spindle speed	40-4000R.P.M.
Spindle motor	AC 7-1/2HP
Quill diameter	φ 110mm (4-5/16")
Quill travel	152mm (6")
Cutting feed	3.5M/min (140 ipm)
Rapid feed	5M/mm (200 ipm)
Floor Space (LxWxH)	3630x2070x2200mm
Weight(Approx.)	3100kgs (6820 lbs)
Packed size	2280x2200x2300cm

Standard accessories:

- 1 .Draw bar
2. Slide ways cover
3. Auto lubrication
4. Coolant system
5. Halogen work light
6. Tools & tool box
7. Pneumatic power draw bar

Optional accessories:

1. Pneumatic power draw bar
2. Electric power draw bar
3. Chip tray
4. Milling chuck w/-
 - a.7 pcs collects
 - b.15 pcs collects
5. Clamping kits
6. Quick change slotting unit
7. Right angle attachment

2.3.2 Constraints on materials

Any material will generate dust or other substances harmful to health and pollute the environment shall be forbidden.

2.3.4 Requirements of operators and servicemen

It is so designed that only a skilled technician is allowed to operate this machine, otherwise he must be trained until knowing how to operate correctly and safely. Qualified technicians shall carry out the electrical maintenance works only.

2.3.5 Requirements of circumstance

It is so designed that this machine cannot be used in the potential explosive environment. Generally, this machine will be installed on the following conditions:

- (1) Ambient temperature: 5-40°
- (2) Atmosphere: Free from excessive dust, acid fume, corrosive gases and salt.
- (3) Avoid exposing to abnormal vibration.
- (4) Avoid exposing to direct sunlight or heat rays, which can change environmental temperature.
- (5) Have to connect to earth.
- (6) Relative humidity: 30~95% (without condensation)
- (7) Source frequency: nominal frequency $\pm 1\%$
- (8) Supply voltage: nominal supply voltage $\pm 10\%$

3. Preparation for installation

3.1 Requirements of foundation

With the common usage of tungsten carbide cutting tools nowadays , heavy cutting and quicker spindle speed are therefore reinforced .This may cause the vibration easily .In order to ascertain the best cutting condition , it is necessary to build a sound & good floor basis .(please refer to following figure)

Fig. 3-2

3.2 Requirements of power supply

Voltage	Steady state voltage 0,9 ... 1,1 of nominal voltage.
Frequency	0,99 ... 1,01 of normal frequency continuously, 0,98 ... 1,02 short time.
Harmonics	Harmonic distortion not to exceed 10% of the total r.m.s. Voltage between the live conductors for the sum of the 2nd through 5th harmonic.
Voltage unbalance in 3-phase supplies	Neither the voltage of the negative sequence component nor the voltage of the zero sequence component shall exceed 2% of the positive sequence component.
Voltage impulses	not to exceed 1,5 ms in duration with a rise / fall time between 500 ns and 500 ns and a peak value not more than 200% of the rated r.m.s supply voltage.
Voltage interruption	Supply interrupted or at zero voltage for not more than 3 ms at any random time in the supply cycle. There shall be more than 1 s between successive interruptions.
Voltage dips	voltage dips shall not exceed 20 % of the peak voltage of the supply for more than one cycle. There shall be more than 1 s between successive dips.

4. Transportation and installation

4.1 Shipping chest

This chest is used to pack the machine for shipment.

Fig. 4-1

4.2 Notices for transportation

- (1) The machine will be moved and bumped caused by braking, turning corner and shaking when the truck moves on the road. Therefore, the machine should be tightening in secure and balanced condition before transporting.
- (2) This machine is a package unit, all the parts should be fixed firmly to link up with the machine before shifting.
- (3) Make sure that the machine is completely fasten with the bottom rack of the chest or carrying rack by means of bolts.
- (4) To avoid coolant and oil leakage and the machine rusting because of moisture during transporting, they shall be drained out completely prior to shifting. However required amounts of them shall be refilled before starting up.
- (5) For the interests of machine safety and personal safety, the hoist driver shall be qualified with a certificate.
- (6) Sunshine and raindrop shall be avoided during transporting.

4.3 Notices for open the shipping chest

- (1) The chest shall be opened by professional personnel with specific tools.
- (2) The top cover shall be dismantled first and second t the side walls.
- (3) Don't open the chest in case of the workers with bad mood.
- (4) After it is uncovered, people who are not professional technician for trial run and service shall be prohibited to wire the power, trial run the machine, dismantle or any else relevant.
- (5) Please refer to the local regulation of environment protection to treat the scraps after the chest was broken.

4.4 Requirement of transportation equipment

4.4.1 Methods of transport

- (1) Machine net weight: approx. 2800 kg.
- (2) Prior to unpacking, transport may be using a forklift.
- (3) After packing, transport may be made by hoisting with a reinforced cable.
 - a. Use the forklift of fork to lift an about 10Cm high. Then put the riser at the bottom.
 - b. Drive the fork to the side of machine and insert the forklift slowly into the space of the bottom. After the base is put on the forklift completely, lift the machine slowly.

NOTE: Must not lift the machine at the side of machine directly, which will overturn the machine.

Remarks:

- (1) Always ensures capacity of equipment is adequate before attempting to lift.
- (2) When the machine is being hoisted, keep the personnel after.
- (3) To hoist the unpacked case by reinforced cable, the motion shall that observe strictly the instruction appeared on the side of the wooden case.
- (4) Keep the worktable and saddle in the proper positions so as to keep the machine balance.
- (5) Do not hoist the machine too high. The best position is to keep the machine base approximately 10cm from the ground.
- (6) Only an authorized forklift or crane operator is allowed to transport the machine.

4.4.2 Cautions for unpacking

- (1). To transport the machine, it is necessary to support the machine with the rated case or pallet to avoid moisture. In case of damage by moistening, please contact our agent or the transported.
- (2). After unpacking, check and see if all tools and accessories are intact, otherwise, please contact our agent.
- (3). After unpacking, do not move the sliding surfaces and worktable as long as the rustproof oil on them are cleaned off and followed with the lubrication.
- (4). Before the cleaning starts, the sliding protective pieces must be dismantled, and all sliding surface setting levers, loosened. When the rustproof oil is removed, proper amount of lubricant should be injected onto various sliding surfaces. Then move the sliding surfaces for final cleansing and lubrication.
- (5). Do not remove the oil brushes in the process of cleaning.
- (6). Do not use gasoline or any other inflammable oil cleaner.

4.5 Notices for installation

B8FC is a precession CNC milling machine, any work related to this machine shall only be by service engineers or qualified technicians. This manual shall be prior to use it.

4.5.1 Work environment

This machine is inadequate for any explosive environment.

4.5.2 Power supply installation

Using a phase-sequence detector to check the correctness of phase sequence (L1, L2, and L3).

4.5.3 Leveling adjustment

- (1) To keep the accuracy and to maintain the good condition of lifetime of this machine, leveling adjustment is one of the important factors. To show the excellent precision and quality of this machine, please carry out leveling accordingly after installation.
- (2) First, a flat ground being able to burden the weight of machine shall be prepared. After positioning the machine on the prepared foundation, then install the machine according to the instruction manual. Roughly leveling the machine by adjusting the leveling bolts at the bottom of machine base. Moving worktable to the X and Y axis middle position place an accurate level 150mm length with a minimum scale of 0.02mm/M (0.0008"/40") on the worktable. Then turning the leveling bolts to make the deviation within 0.02mm/M (0.0008"/40").
- (3) If vibration occurs due to ill horizontality or cutting scared defective condition occurs, leveling shall be re-tuning again.
- (4) Within 2 or 3 days after installing completed, the horizontal should be re-checked before operating. Under normal working condition, the horizontal shall be examined in a period of half year initially and then quarterly in the subsequent years.

5. Preparation for trial runs

5.1 Cleaning

All machine surfaces are covered with rust preservative, which must be thoroughly cleaned before moving any parts of the machine. Only mild solvent and soft rags must be used for cleaning.

NOTE: Never use lacquer, thinner, gasoline or other inflammable as a cleaning fluid.

5.2 Visible inspection

At first, removing any stopper used to prevent the machine from movement in transportation (e.g. the doorplates). Check if the machine is rusted and damaged as well as shape transformed, broken, etc. Any fault shall be removed prior to trial run.

5.3 Fluids

Lubricant and coolant shall be filled to designated quantities first. Referring to section 7.4 to perform maintenance to maintain the machine for operating in good condition.

5.4 Electrical earthing system

Make sure that a stable power voltage as well as the frequency for NC unit wires the machine. The machine should be earthen properly to protect the NC unit from any electric shock.

A: Connecting terminal.

L1,L2,L3: Power cables above 5.5 mm^2

PE: Protective earthing cable above 5.5 mm^2

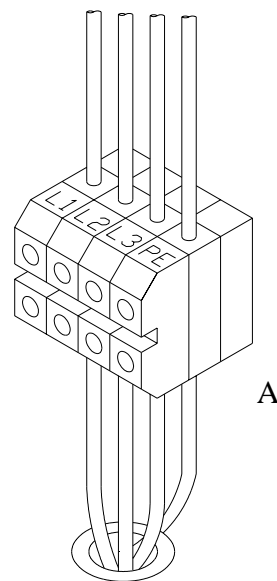

Fig. 5-1

6. INSTRUCTIONS IN OPERATIONS

6.1 HEAD STOCK

6.1.1 MANUAL FEED:

The manual feed lever is installed on the right side of head stock.(vide FIG.6-1) The spindle will vertically when the lever is turn. An operator can freely take out the lever and install it again at the position deemed proper and fit.

NOTE : In manual feed, the feed control handle must be placed at position (F) as shown in (FIG 6-1).

6.1.2 MANUAL MICRO MOTION FEED:

To effectuate the manual micro motion feed, the power feed transmission engagement crank (J) (FIG 6-1) shall be placed at "OUT" position, and feed reverse knob (d), at the neutral position.Feed control lever (F) must be pulled from (F1) to (F2). This is to engage the overload clutch. Turn the feed hand wheel (E) clockwise for quill downward feed, and vice-versa.

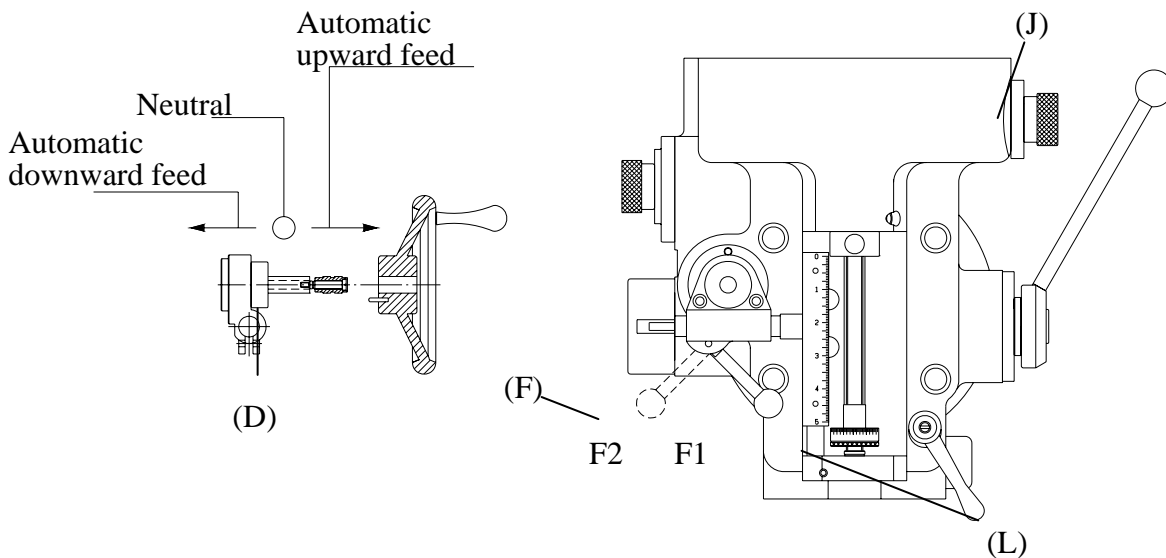

FIG6-1

6.1.3 (AUTOMATIC FEED)

For automatic feeding; please take the following steps(vide FIG.6-1)

- (1). Loosen the quill lock (L) .
- (2). Turn the power feed transmission engagement crank.
- (3). Feed speed is in three stages. H, L and M. selection may be made by quill feed elector.

- (4). Pull the feed control lever (F) from (F1) to (F2) position (FIG.6-2) to engage the overload clutch for automatic feed mechanism.
- (5). When the feed control lever knob (D) is pressed inward (FIG 6-1), it is for downward feed; and vice-versa: The middle position is neutral.
- (6). As shown in (FIG 6-2), the working depth may be set by micrometer adjustment nuts (K) (each graduation is 0.001" or 0.02 mm). When the quill stop block (I) contacts the micrometer nut (K), the feed control lever (F) may simply jump from (F2) back to (F1) position owing to the connecting motion between the feed trip lever and feed trip plunger. This will disengage the overload clutch and stop the spindle feed.

NOTE : 1. Maximum drilling capacity in automatic feed is 3/8" or 10mm.

2. The power feed transmission engagement crank (J) (FIG.6-1)
3. Shall be placed at "out" position when the automatic feed is not in operation.
Do not move the power feed transmission engagement crank when the spindle is in revolution.

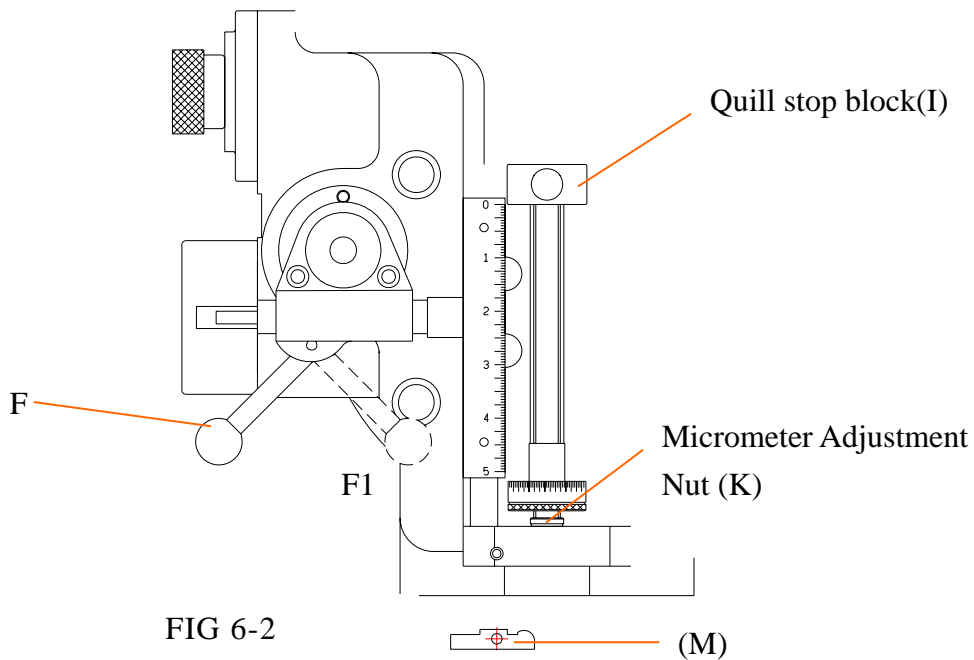

FIG 6-2

6.1.4 HEADSTOCK CROSS TILTING

Loosen evenly the four nuts (R) and turn the worm shaft (S) until the desired angle is secured .

Then lock up the lock nuts evenly.

NOTE: Do not loosen the lock nuts (R) totally during the adjustment.

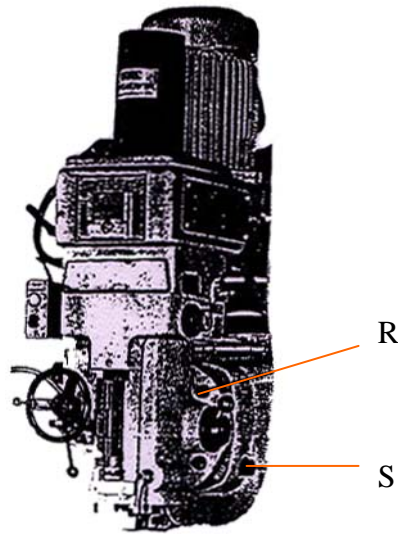

FIG.6-3

6.1.5 SPEED CHANGE OF SPINDLE

Change of high and low speed:

The speed change may be effectuated by the chosen high and low speed lever(FIG 6-4(J)). When(J) is engaged in the right front, it is for the high speed and the spindle rotate as high as 260 or 3950 rpm. The neutral lever position is in the right down.

H	64	130	192	256	320	395
	26	51	77	102	128	153
L	11	21	32	42	53	65
	4	8	13	17	21	26

NOTE: a. The spindle must be motionless completely during the speed change.

b. To shift the high speed into the low one, the spindle must be slightly turned to make it easier for the back row gear to engage.

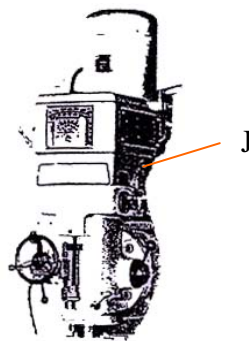

FIG.6-4

7. Lubrication & coolant

7.1 Headstock lubrication

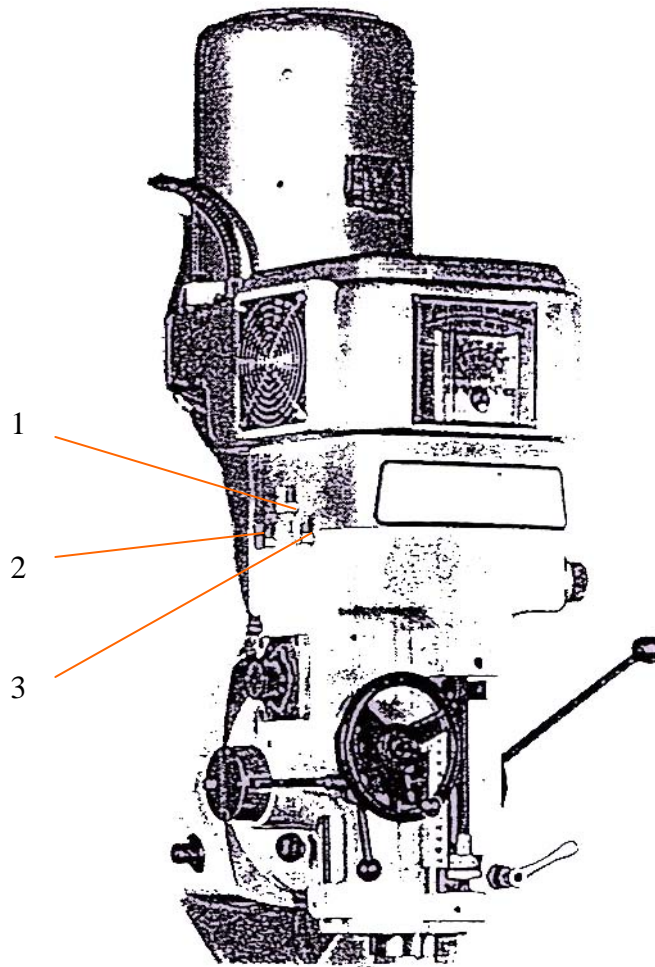

Fig. 7-1

NO	LUBRICANTS	QTY.	TIME
1	KUO-KUANGR68 ESSO FEBIS K35	FULL	DAILY
2	KUO-KUANGR68 ESSO FEBIS K35	FULL	DAILY
3	KUO-KUANGR68 ESSO FEBIS K35	FULL	DAILY

7.2 Spindle

Bearing in the spindle are forced lubricated at the assembling by grease. This high-speed Grease is a low-temperature and long-term grease, especially for high-speed rolling bearings or high load.

When the machine does not be operated for a long time (more than 7 days), you should perform the spindle at low speed about one hour before the operation.

7.3 Lubrication Tank and Pipe Drawing

Lubrication tank supplies the lubricant for x axis, y axis, z axis ball screw and slide way. The adjustment of discharge is to pull out the snap ring and fix the discharge of you need (3~6 cc/cycle).

First use this pump from the lubrication tank must pull up the handle continuous until oil.

Fill in the empty pipes for normal application. You must refill oil when the oil surfaces below the low line.

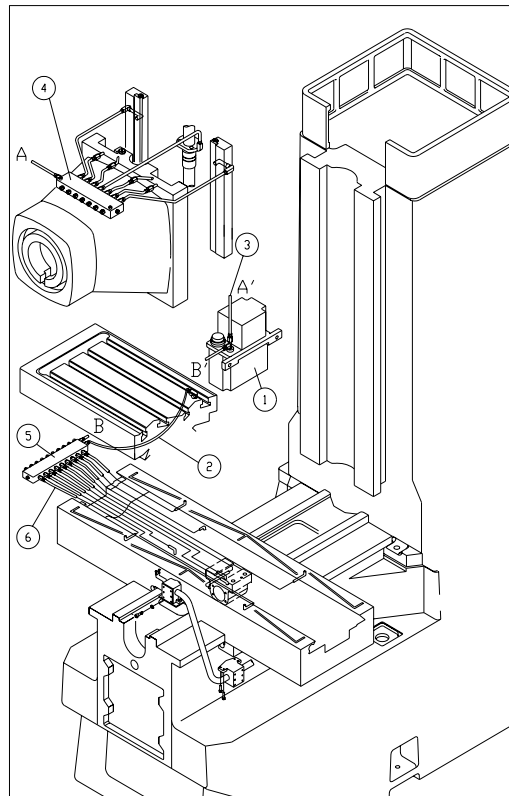

Fig. 7-2

NO	DESCRIPTION	QTY	SPECIFICATION
1	Electronic Lubrication	1	CSED TYPE
2	Lubrication String	1	ø4x1000mm
3	Lubrication String	1	ø4x1000mm
4	Oil Distribute	1	A29
5	Oil Distribute	1	A-12
6	Lubrication Oil Tubing	17	ø4

7.4 Coolant replacement

The sump locates in the base of the machine. The volume of the sump is 160 liters.

1. Turn off the power source.
2. The dirty coolant is drained through the drain plug on the back of the machine base.
3. Supply fresh coolant through the filter into the sump.

Table of coolant usage

Material	Recommendation	PERIOD
Ferrous materials	A RAL SAROL 345	4 month
Cast iron	ARAL MULTROL 820	
Else materials	Any suitable coolant. Do not use low flash point coolant. Adequate coolant with little or no harm to health.	

Notice:

The old coolant handling should comply with the local usage.

8. Adjustment

As a result of long-term operation between the sliding surface and gibs will create a clearance. Therefore the gibs must be adjusted to upkeep the precision of sliding surfaces.

8.1 Adjustment of work table gibs

The gibs are attached onto between the saddle seat and worktable dovetail.

- (1) Clean the slide way and add the lubricant.
- (2) Use a screwdriver and spanner adjusts the gib screw and nut (M) on both sides of saddle seal.
- (3) Replace the excessive worn-out gib whenever necessary.

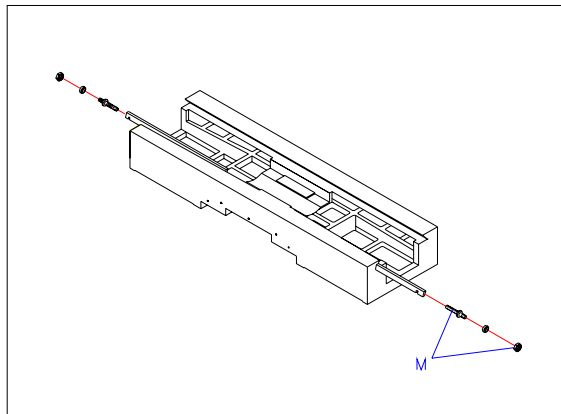

Fig. 8-1

8.2 Adjustment of saddle gib

- (1) Move the saddle to the front of base.
- (2) Clean the slide way and add the lubricant.
- (3) Use screwdriver to adjust the gib screw (D) of the saddle.
- (4) Employ the same methods to adjust the work table gib.

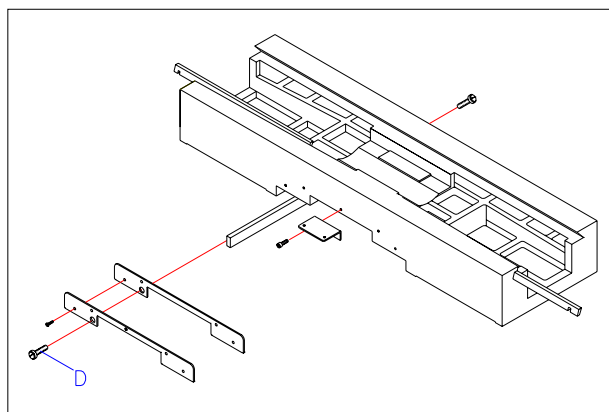

Fig. 8-2

8.3 Adjustment of elevating gib

The elevating gib is attached to the precision of elevating and column dovetail. The adjustment can be performed as follows:

- (1) Clean the slide way and add the lubricant.
- (2) Use a screwdriver to adjust the gib screw (R) of the elevating.
- (3) Employ the same methods to adjust the word table gib.

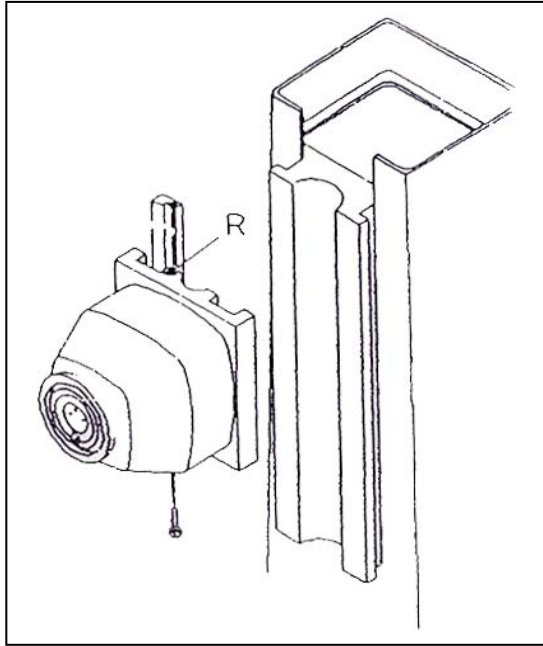

Fig. 8-3

9. Service and maintenance

9.1 Belt maintenance

- (1) When the abnormal belt is discovered; please exchange or adjust the belt immediately. Because of tightness, looseness, transforming and friction ill make noise and have an effect on belts lifetime.
- (2) Belt transmission should be examined the status of transmitting, noise and efficiency etc. to prevent abnormal status occurred.
- (3) In case of exchange, the sharp tools are avoided to use the belt may be damaged to influence transmitting efficiency and lift time of belt.
- (4) In case of machine stops operating more than 6 months, the belt should be loosened to prevent fatigue from long-time tension.

9.2 Lubricant system maintenance

Eyes examine the pipe loop way at particular period (especially over one year). In order to prevent pipe loop fallen leaked, broken, stress fold. Blocked all lubricant parts should be lubricated sufficiently.

9.3 Cutting coolant system maintenance

- (1) The purpose to use coolant is to reduce thermal transformation while processing, also, the normal accuracy of workplace can be kept and the tool lift time increased. So that the coolant can be selected properly depending on the sort of materials of workplace.
- (2) Dependence on the degree of pollution, the coolant should be changed regularly and avoids physical damage of worker and influence the accurate precise of workplace. According to the tankard of environmental protection.
- (3) The polluted coolant should be treated by treatment system, before drained off. Be cautioned the polluted coolant is treated incorrect method when drained out. The human health and environment will be damaged.

9.4 Electricity maintenance

- (1) All wiring shall be examined damage by eyes at particular period.
- (2) Prevention outside substances more into the control case and operation case due to human omission. This will cause short-circuiting.
- (3) Check and confirm all L.S. signals at particular period.
- (4) Clean up ventilator filter and check all vent hold of electrical control box at particular period.
- (5) The rotating of main motor's cooling fan shall be confirmed.

9.5 Maintenance measures for critical safety devices

The critical safety devices are particularly relating to safety.

In order to give those device healthy operation conditions, it is necessary to perform maintenance procedure as per the following table.

Device	Description of Maintenance
E-Stop	Pushing the Emergency stop button after daily starting up according to Operator's Manual. A "NOT READY" message displayed on screen means E-stop is healthy; otherwise, it is faulty and shall have a service by qualified technician.
Main Power Switch	Checking the tightness of holder every half year, if it is loose it must be tightened. If the fixing screw between the holder and link wears, replacement shall be changed according to the specification on the electrical parts list.
Lubricant Tank	Lubricant must be filled if lubricant shortage message displayed on CRT.
Door interlock switch	After daily starting up according to Operator's Manual and with door being closed, if the door can be open without key switch, it means the Door Interlock Switch is abnormal and shall have a service by qualified technician.

9.6 Cleaning for chip

- (1) At first, open the door then turn off main power supply.
- (2) The operator should wear safety shoes, helmet; safety glove, safety glassed and clothes.
- (3) Use besom, hair brush and dustpan clean chip.

10. Self service and dismantling

10.1 Main tenance precaution

When unit parts of this machine is fixed, the specific tool equipment are required.
And only the experienced professional technician is allowed to repair machine.

In case unit parts out of order, as electricity controller, ball screw linear way, and so on.
The unit parts can not be dismantled and fixed arbitrarily by you. You may contact our agencies if service needed.

10.2 Safety confirmation

Turn the main power off and set up warning signs at each side surrounding the achiever with 3 meters; if the machine is disassembled and fixed.

10.3 Requirements of replacement

For safety and keeping accurate quality and sort of unit parts should be used as the same as the original designed specification and manufacture brand, while exchanging or fixing needed.

10.4 Dismantling of motor cas showing

- a. Cut off motor power source
- b. Loosen the two motor lock nut handle (A)
- c. Take off the two lock bolt handle (B) that locked the motor. The motor may be lifted up.

Motor speed change belt are still kept inside the belt housing.

- d. Once the motor is replaced, just reverse the order of dismounting.

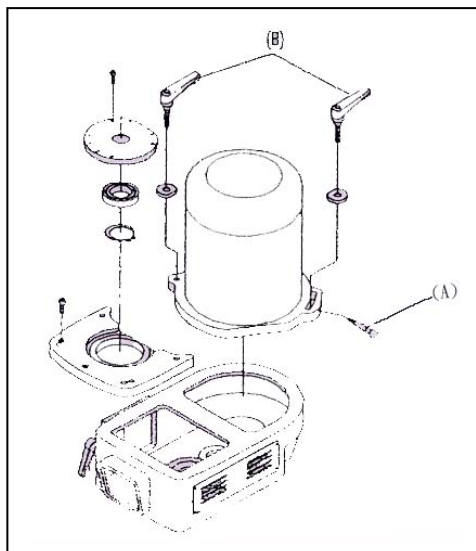

Fig.10-1

10.5 Replacement of speed change belt (I)

- a. Turn off the power source.
- b. Take off draw bar.
- c. Dismantle the four round screws (C) and take off the ventilator (D).
- d. Loosen the two lock bolt handle that locked the motor.
- e. Dismantle the three hexagonal socket head screws (G) and use two of them to lift the bearing housing (H).
- f. Dismantle the four hexagonal socket head screws (F) and lift the change housing (I).
- g. Take off the spacer (J) and gear (K)
- h. When the speed change belt is replaced accordingly, restore the machine by reversing the orders.

NOTE: The replaced speed change belt shall conform to that of our company specifications.

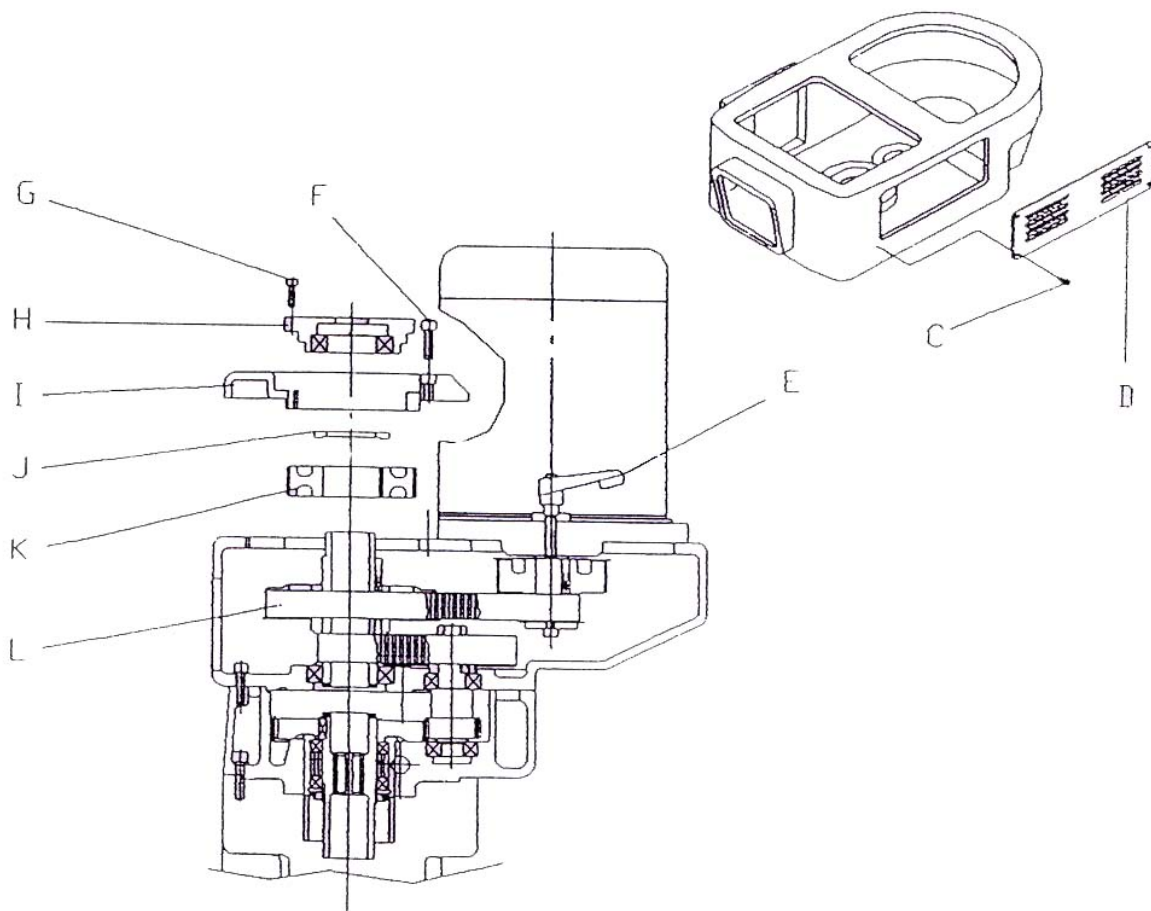

Fig. 10-2

10.6 Replacement of HI-LO speed change belt (n)

- a. Refer to step A to H of replacement of speed change belt.
- b. Lift the gear (M) to position (P).
- c. When the speed change belt is replaced accordingly, restore the machine by reversing the orders.

NOTE: The replaced speed change belt shall conform to that of our company specification.

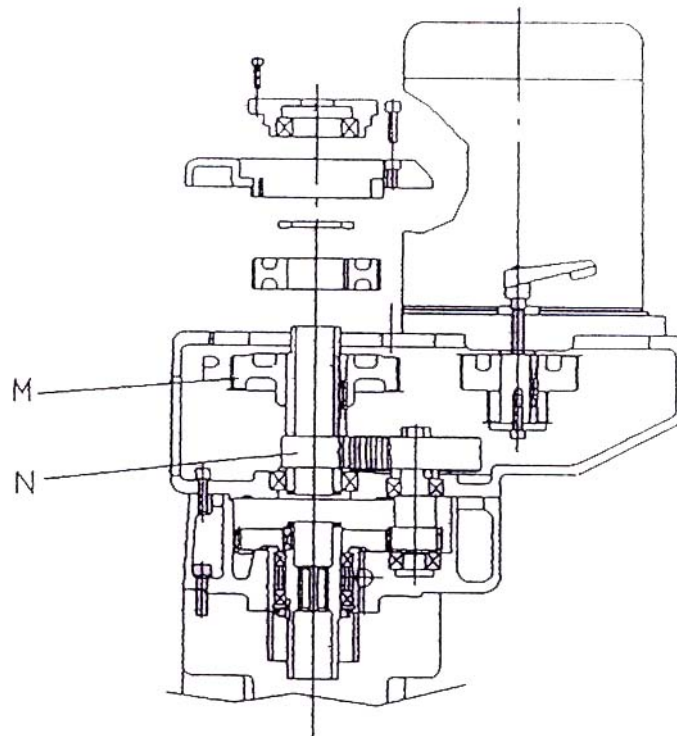

Fig. 10-3

10.7 Inspection and maintenance period list

10.7.1 Inspection

No	Item	Inspection detail	Period
1	Voice	In operation, checked to see if the machine were abnormal voice.	Daily
2	Vibration	In operation, checked to see if the machine were abnormal voice.	Daily
3	Temperature	After operating, checked to see if the head stock temperature were too high.	Daily
4	Motor	Checked to see if the spindle motor were run correct.	Daily
5	Lubrication	Checked to see if the lubrication oil were correct.	Weekly
6	Cleaning	Checked to see if the machine were cleaning.	Weekly
7	Button	Checked to see if the push button were acumen.	Monthly

10.7.2 Maintenance

No	Maintenance detail	Period
1	In case of machine stops operating the belt should loosened to prevent fatigue from long-time tension.	6 months
2	The pipe loop way be examined by eyes at particular period.	Especially over one year
3	Dependence on the degree of pollution, the coolant should be changed.	4 months
4	All wiring shall be examined damage by eyes at particular period.	1 month

11. Troubles and trouble shooting

11.1 X axis, Y axis and Z axis

- (1) Problem: The longer of processing, the shorter of the finished dimension.
Remedy: Please examines the precision screw nut and motor bolt, whether they are loose.
- (2) Problem: The dimension drift is too sensitive to temperature.
Remedy: the precision bearings are over pre-loaded, please adjust.
- (3) Problem: Zero return fails.
Remedy: Check the dog and proximity sensor.
- (4) Problem: Abnormal noise and vibration occurred in motion.
Remedy: Check the bearings, ball screw, and linear ways.
- (5) Problem: Doesn't work.
Remedy: Check the PCB and wiring.

11.2 Coolant system

- (1) Problem: Coolant ejected out over volume.
Remedy: Check the piping and the pollution degree of coolant and the pump suction inlet.
- (2) Problem: The coolant drains back if not in use.
Remedy: check the checking valve.

11.3 Lubricant system

- (1) Problem: Lubricated mechanical parts out of lubricant.
Remedy: Check the lubricator and piping.
- (2) Problem: Improper oil supply
Remedy: Check the lubricator and the specification of lubricant.

11.4 Electricity

- (1) Problem: Abnormal secondary power.
Remedy: Check the wiring if there is short-circuit or disconnection.
- (2) Problem: The program processing halted.
Remedy: Check the circuits and connecting cables.

12. PARTS LIST

12.1 HEAD STOCK UPSID (1) DRAWING

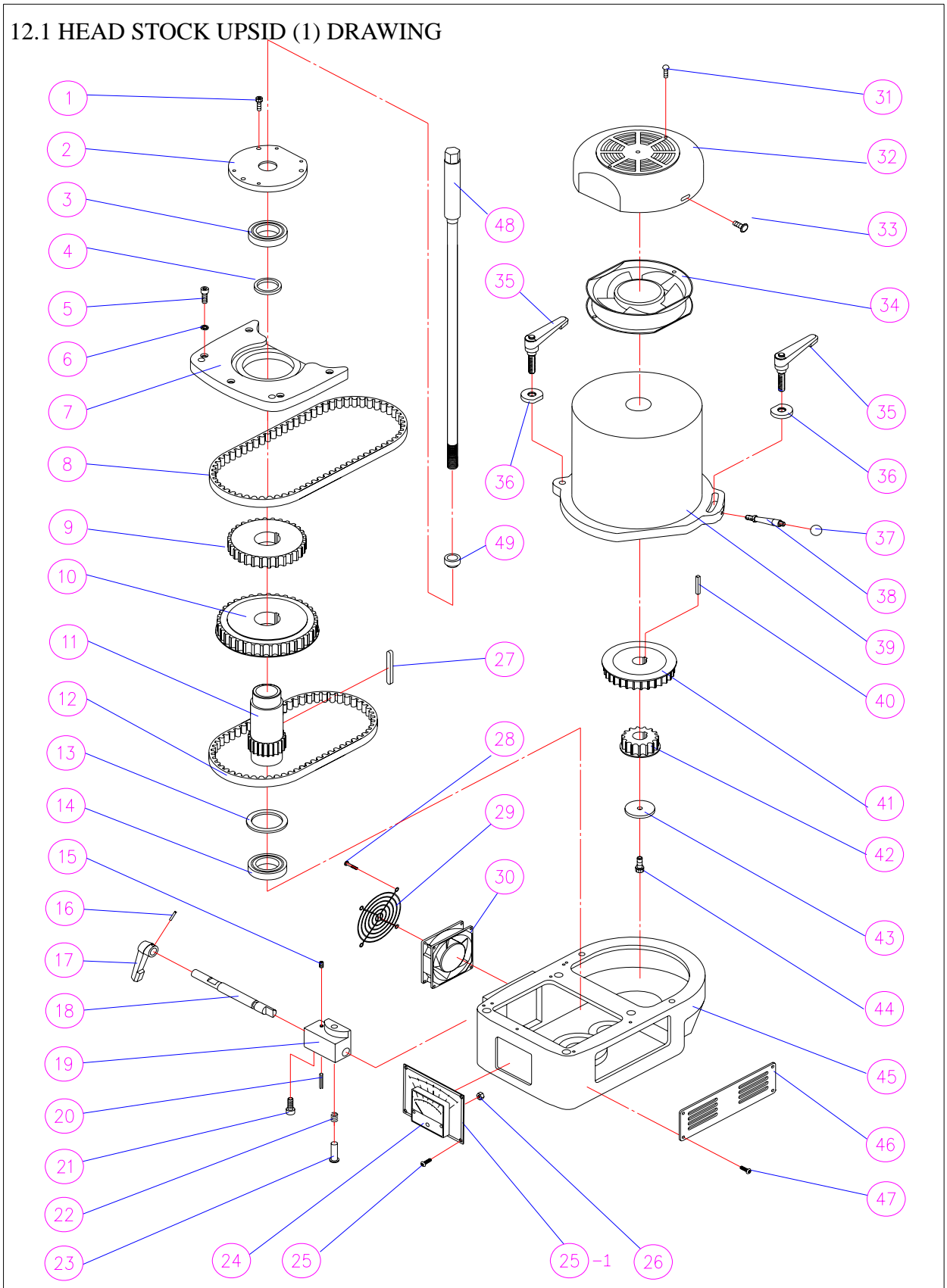

HEAD STOCK UPSIDE (1) PARTS LIST

NO.	PART NO.	DESCRIPTION	QTY
1.	SC-M6x20L	SOCKET CAP SCREW	4
2.	K6-K042-00	TOP BEARING CAP	1
3.	6009LLB	BALL BEARING	1
4.	K6-K043-00	SPACER	1
5.	SC-M6x30L	SOCKET CAP SCREW	5
6.	WF-ø6	FLAT WASHER	4
7.	K6-K005-00	CHANGE HOUSING	1
8.	8M-25-720	HTD BELT	1
9.	K6-K054-00	GEAR 47T	1
10.	K6-K052-00	GEAR 62T	1
11.	K6-K045-00	SPINDLE GEAR HUB	1
12.	8M-25-480	HTD BELT	1
13.	K6-K047-00	SPACER	1
14.	6010LLB	BALL BEARING	1
15.	SS-M6x6L	SOCKET SET SCREW	1
16.	SP-ø3x20L	SPRING RIN	1
17.	K6-K125-00	HANDLE	1
18.	K6-K128-00	SHIFT CRANK	1
19.	K6-K132-00	PINION BLOCK	1
20.	SP-ø5x30L	SPRING PIN	2
21.	SC-M8x20L	SOCKET CAP SCREW	2
22.	SG-ø13d2-25L	SPRING	1
23.	K6-K129-00	PLUNGER	1
24.	YM-8	FREQUENCY METER	1
25.	SR-M4x8L	ROUND HEAD SCREW	4
25-1.	PM-GE15	SPINDLE SPEED PLATE	1
26.	HN-M4	NUT	2
27.	KY-8x8x70L	KEY	1
28.	SR-M4x35L	HEAD ROUND SCREW	4
29.	F4-K008-00	AIR BLOWER NET	1
30.	SF23092A	AIR BLOWER	1
31.	SR-M6x10L	HEAD ROUND SCREW	2
32.	F4-K009-00	MOTOR AIR BLOWER COVER	1
33.	SR-M5x10L	HEAD ROUND SCREW	4
34.	GF172	AIR BLOWER	1
35.	K6-K026-00	LOCK BOLT	2
36.	K6-K027-00	WASHER	2
37.	BB-ø1/4"	BRACELET BALL HANDLE	1
38.	K2-S006-00	MOTOR LOCK NUT HANDLE	1
39.	K6-K007-00	SPINDLE MOTOR	1
40.	KY-8x7x50L	KEY	1
41.	K6-K033-00	GEAR 40T	1
42.	K6-K036-00	GEAR 21T	1
43.	K6-K037-00	WASHER	1
44.	SC-M8x20L	SOCKET CAP SCREW	1
45.	K6-K001-00	BELT HOUSING ASSEMBLY	1
46.	K6-K164-00	VENTILATOR	1
47.	SR-M5x10L	ROUND HD SCREW	4
48.	K4-K147-00	DRAWBAR	1
49.	K4-K149-00	DRAWBAR WASHER	1

12.2 HEAD STOCK UPSIDE (2) DRAWING

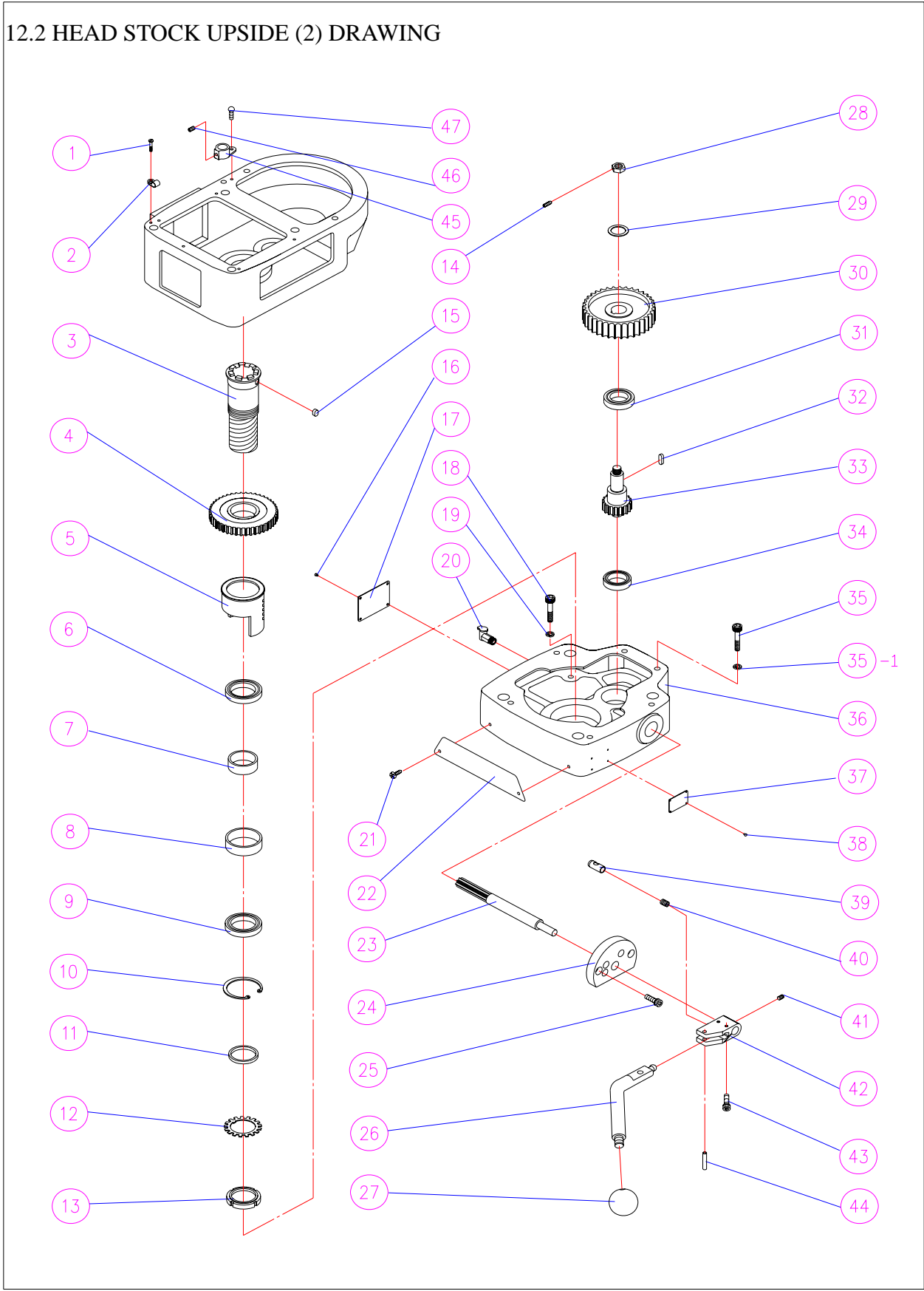

HEAD STOCK UPSIDE (2) PARTS LIST

NO.	PART NO.	DESCRIPTION	QTY
1.	SR-M5x6L	ROUND HEAD SCREW	1
2.	UC-1	CABLE CLAMPS	1
3.	K6-K101-00	SPINDLE GEAR HUB	1
4.	K6-K100-00	SPINDLE BULL GEAR ASSEMBLY	1
5.	K4-K105-00	BEARING SLEEVE	1
6.	6910LLB	BALL BEARING	1
7.	K4-K111-00	BEARING SPACER	1
8.	K4-K110-00	BEARING SPACER	1
9.	6910LLB	BALL BEARING	1
10.	R-72	SNAP RING	1
11.	K4-K103-01	WASHER	1
12.	AW-10	TOOTH WASHER	1
13.	K4-K104-00	LOCK NUT	1
14.	SS-M6x6L	SOCKET SET SCREW	1
15.	KY-8x8x18L	KEY	1
16.	RT-ø2x5L	RIVER	4
17.	PM-GE13	PLATE	1
18.	SC-M10x35L	SOCKET CAP SCREW	4
19.	WS-ø10	SPRING WASHER	4
20.	OC-1/8" PT	OIL CAP	1
21.	SR-M5x10L	ROUND HEAD SCREW	2
22.	PM-BT12	NAME PLATE	1
23.	K5-K136-00	BULL GEAR SHIFT PINION	1
24.	K6-K137-00	HI-LOW DETENT PLATE	1
25.	SC-M5x12L	SOCKET CAP SCREW	2
26.	K2-K145-00	HI-LOW SHIFT CRANK	1
27.	BB-ø1/4"	BRACELET BALL HANDLE	1
28.	HN-5/8"	NUT	1
29.	WS-ø5/8"	SPRING WASHER	1
30.	K6-K119-00	PULLEY	1
31.	6205ZZ	BALL BEARING	1
32.	KY-8x8x25L	KEY	1
33.	K6-K114-00	BULL GEAR PINION COUNTER SHAFT	1
34.	6204ZZ	BALL BEARING	1
35.	SC-M8x25L	SOCKET CAP SCREW	7
35-1.	WS-ø8	SPRING WASHER	7
36.	F4-K003-00	GEAR HOUSING	1
37.	RT-PM-GE22	QUILL FEED WARNING PLATET	1
38.	RT-ø2x5L	RIVET	4
39.	K2-K144-00	HI-LOW DETENT PLUNGER	1
40.	K2-K143-00	SPRING	1
41.	SS-M5x6L	SOCKET SET SCREW	1
42.	K2-K141-00	HI-LOW PINION BLOCK	1
43.	SC-M4x16L	SOCKET CAP SCREW	1
44.	SP-ø4x16L	SPRING PIN	1
45.	K5-5054-00	CABLE CLAMPS	1
46.	SS-M6x8L	SOCKET SET SCREW	1
47.	SR-M5x10L	ROUND HEAD SCREW	1

12.3 HEAD STOCK INFRASTRUCTURE (1) DRAWING

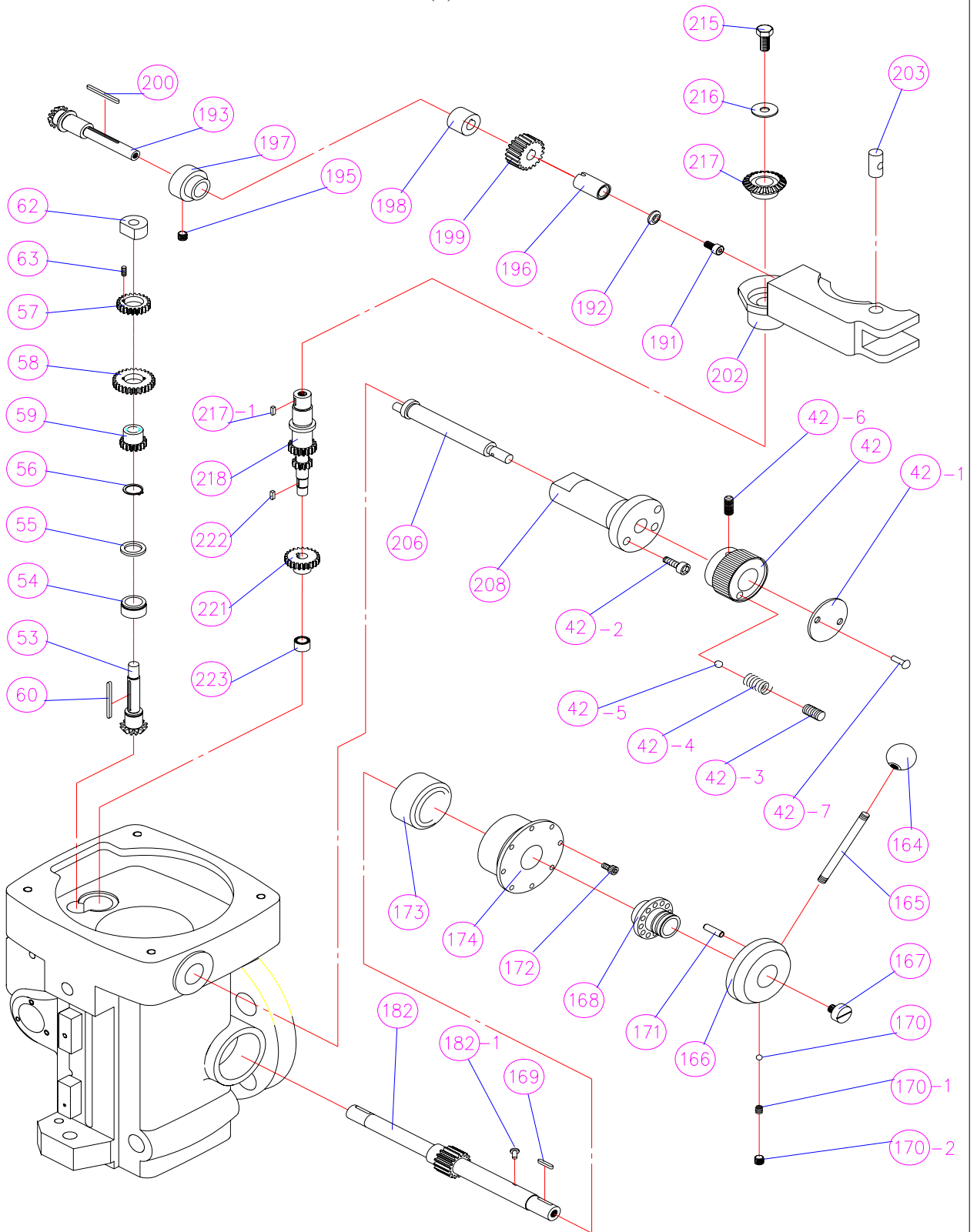

HEAD STOCK INFRASTRUCTURE (1) PARTS LIST

NO.	PART NO.	DESCRIPTION	QTY
42.	K5-A042-00	SHIFTER CRANK	1
42-1.	K5-A042-10	PLATE	1
42-2.	SC-M5x12L	SOCKET CAP SCREW	1
42-3.	SS-M6x6L	SOCKET SET SCREW	1
42-4.	K5-A040-00	COMPRESSION SPRING	1
42-5.	BS-ø6	STEEL BALL	1
42-6.	SS-M6x10L	SOCKET SET SCREW	1
42-7.	RT-ø2x5L	RIVET	2
53.	K2-A053-00	FEED REVERSE BEVEL PINION	1
54.	K2-A054-00	BEVEL GEAR BEARING	1
55.	K2-A055-00	BEVEL GEAR THRUST WASHER	1
56.	S-16	SNAP RING	1
57.	K2-A057-00	FEED DRIVE CLUSTER GEAR (UPPER)	1
58.	K2-A058-00	FEED DRIVE CLUSTER GEAR (ENTER)	1
59.	K2-A059-00	FEED DRIVE CLUSTER GEAR	1
60.	KY-3x3x45L	KEY	1
62.	K2-A062-00	TRIP SHAFT BUSHING	1
63.	SS-M4x10L	SOCKET SET SCREW	1
164.	BB-3/8"	BLACK PLASTIC BALL HANDLE	1
165.	K2-A165-00	PINION SHAFT HUB HANDLE	1
166.	K2-A166-00	PINON SHAFT HUB	1
167.	K2-A167-00	PINION SHAFT HUB SCREW	1
168.	K2-A168-00	PINION SHAFT HUB SLEEVE	1
169.	KY-3x3x18L	KEY	1
170.	BS-ø5	STEEL BALL	1
170-1.	K2-A170-A0	SPRING	1
170-2.	SS-5/16"x5/16"	SOCKET SET SCREW	1
171.	K2-A171-00	ROLL PIN	1
172.	K2-A172-00	SOCKET SET SCREW M5x10	2
173.	K4-A173-00	CLOCK SPRING	1
174.	K4-A174-00	SPRING COVER	1
182.	K4-A182-00	QUILL PINION SHAFT	1
182-1.	K2-A182-A0	PIN	1
191.	SR-M6x12L	ROUND HEAD SCREW	1
192.	K2-A192-00	BEVEL PINION WASHER	1
193.	K4-A193-00	FEED BEVEL PINION	1
195.	SS-M6x6L	SOCKET SET SCREW	1
196.	K4-A196-00	FEED WORM GEAR SHAFT SLEEVE	1
197.	K2-A197-00	WORM CRADLE BUSHING	1
198.	K4-A198-00	WORM GEAR SPACER	1
199.	K2-A199-00	FEED DRIVE WORM GEAR	1
200.	KY-3x3x25L	KEY	1
202.	K4-A202-00	WORM GEAR CRADLE	1
203.	K2-A203-00	FEED ENGAGE PIN	1
206.	K5-A206-00	WORM GEAR CRADLE THROW-OUT	1
208.	K5-A208-00	SHIFT SLEEVE	1
215.	SC-M8x16L	SOCKET CAP SCREW	1
215-1.	WS-ø8	SPRING WASHER	1
216.	WF-ø5/6"	FLAT WASHER	1
217.	K2-A217-00	FEED REVERSE BEVEL GEAR	1
217-1.	KY-3x3x10L	KEY	1
218.	K5-A218-00	FEED DRIVING GEAR	1
221.	K2-A221-00	FEED DRIVE GEAR	1
222.	KY-3x3x8L	KEY	1
223.	B-66	TORRINGTON NEEDLE BEARING	1

12.4 HEAD STOCK INFRASTRUCTURE (2) DRAWING

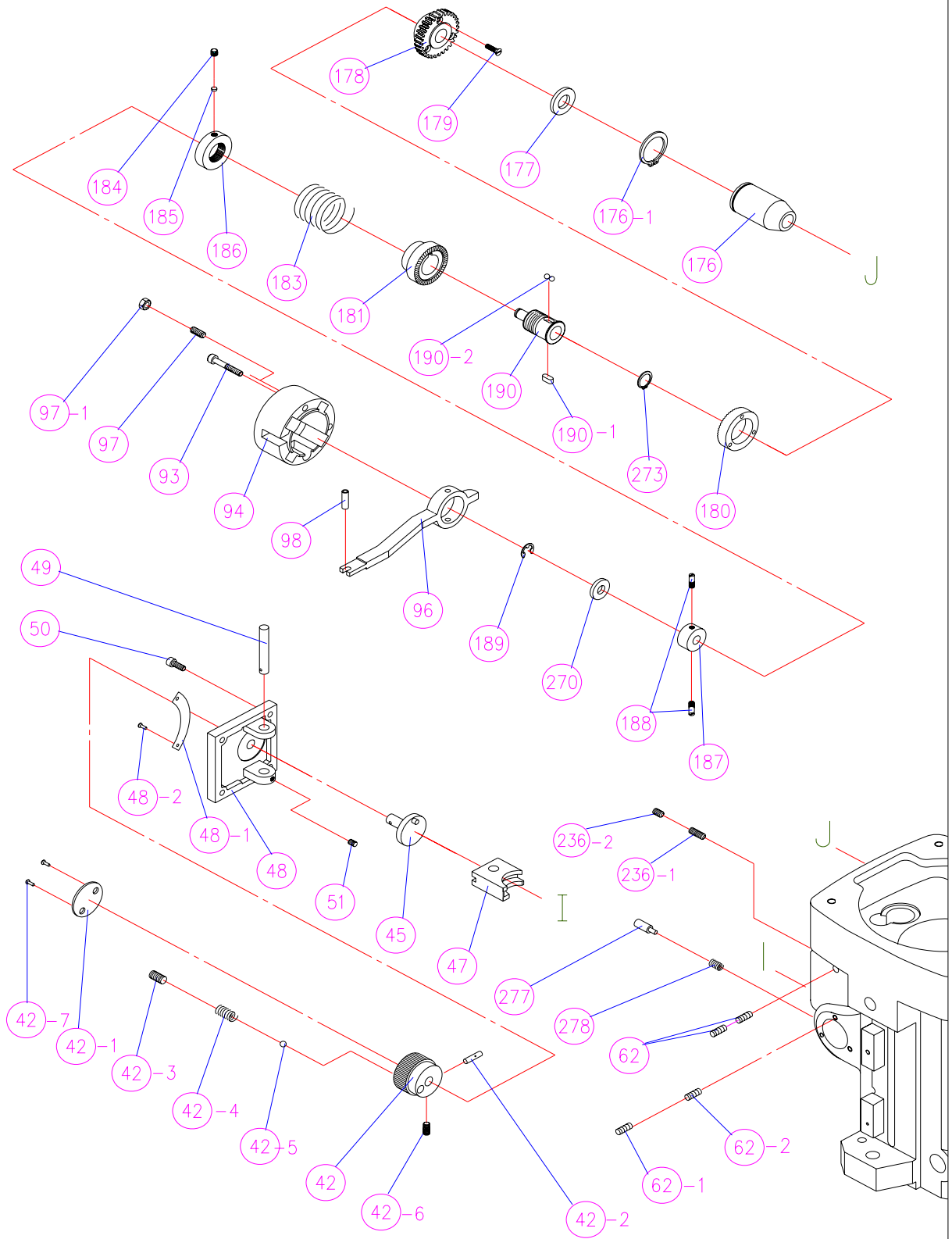

HEAD STOCK INFRASTRUCTURE (2) PARTS LIST

NO.	PART NO.	DESCRIPTION	QTY
42.	K5-A042-00	SHIFT CRANK	2
42-1.	K5-A042-10	NAME PLATE	1
42-2.	SP- ϕ 3x30L	SPRING PIN	1
42-3.	SS-M6x6L	SOCKET SET SCREW	1
42-4.	K5-A042-40	COMPRESSION SPRING	1
42-5.	BS- ϕ 6	STEEL BALL	1
42-6.	SS-M6x6	SET SCREW	1
42-7.	RT- ϕ 2x5L	RIVET	2
45.	K5-A045-00	CLUSTER GEAR SHIFT CRANK	1
47.	K2-A047-00	FEED GEAR SHIFT FORK	1
48.	K4-A048-00	CLUSTER GEAR COVER	1
48-1.	PM-G26	QUILL FEED SPEED PLATE	1
48-2.	RT- ϕ 2x5L	RIVET	2
49.	K2-A049-00	FEED SHIFT ROD	1
50.	SC-M5x15L	SOCKET CAP SCREW	4
51.	SS-M5x5L	SOCKET SET SCREW	1
62.	SS-M6x6L	SOCKET SET SCREW	2
62-1.	SS-M6x6L	SOCKET SET SCREW	1
62-2.	SS-M6x8L	SOCKET SET SCREW	1
93.	SC-M5x35L	SOCKET CAP SCREW	2
94.	K2-A094-00	CLUTCH ARM COVER	1
96.	K5-A096-00	OVERLOAD CLUTCH TRIP	1
97.	1/4"x3/4"	SOCKET SET SCREW	1
97-1.	1/4"	NUT	1
98.	SP- ϕ 5x15L	SPRING PIN	1
176.	K2-A176-00	QUILL PINON SHAFT BUSHING	1
176-1.	K2-A176-A0	SNAP RING S-32	1
177.	K2-A177-00	PINION SHAFT WORM GEAR SPACER	1
178.	K2-A178-00	OVERLOAD CLUTCH WORM GEAR	1
179.	SR-M4x13L	ROUND HEAD SCREW	3
180.	K2-A180-00	OVERLOAD CLUTCH RING	1
181.	K2-A181-00	OVERLOAK CLUTCH	1
183.	K2-A183-00	SAFETY CLUTCH SPRING	1
184.	SS-M6x6L	SOCKET SET SCREW	1
185.	K2-A185-00	SPACET	1
186.	K2-A186-00	OVERLOAD CLUTCH ADJUSTABLE NUT	1
187.	K2-A187-00	OVERLOAD CLUTCH RING	1
188.	K2-A188-00	OVERLOAD CLUTCH RING PIN	2
189.	E-8	SNAP RING	1
190.	K2-A190-00	OVERLOAD CLUTCH SLEEVE	1
190-1.	KY-5x5x12	KEY	1
190-2.	SB- ϕ 6	STEEL BALL SET SCREW	2
236-1.	SS-M6x10L	SOCKET SET SCREW	1
236-2.	K2-A236-B0	A236 SOCKET SET SCREW	1
270.	K2-A270-00	WASHER	1
273.	S-15	SNAP RING	1
277.	K2-A277-00	PIN	1
278.	K2-A278-00	COMPRESSION SPRING	1

12.5 HEAD STOCK INFRASTRUCTURE (3) DRAWING

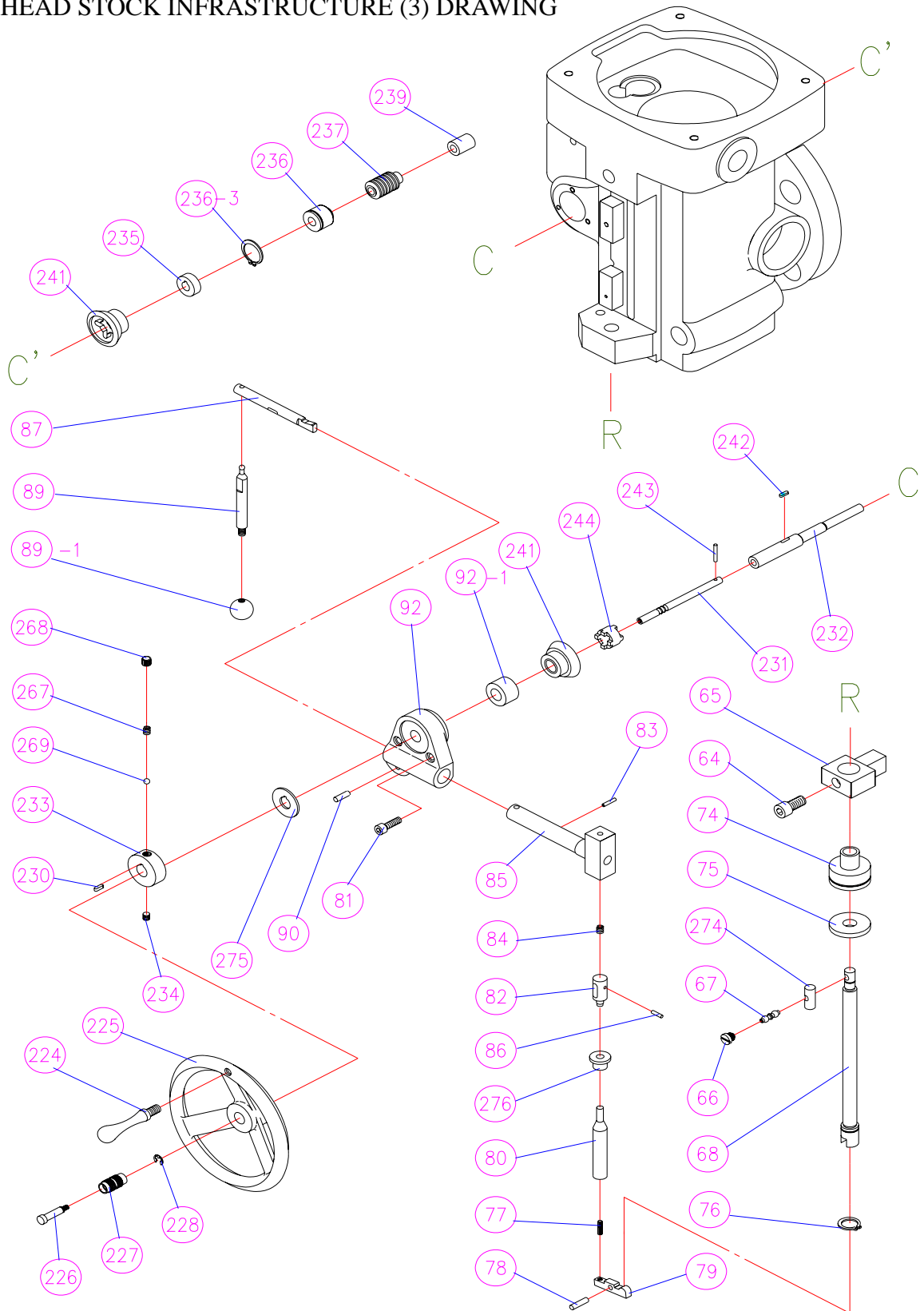

HEAD STOCK INFRASTRUCTURE (3) PARTS LIST

NO.	PART NO.	DESCRIPTION	QTY
64.	SC-3/8" x 3/4"	SOCKET CAP SCREW	1
65.	K6-A065-00	QUILL STOP KNOB	1
66.	K2-A066-00	REVERSE TRIP BALL LEVER SCREW	1
67.	K2-A067-00	REVERSE TRIP BALL LEVER	1
68.	K5-A068-10	QUILL STOP MICRO SCREW (IMPERIAL)	1
74.	K2-A074-10	DIAL WITH 50 GRADUATIONS (IMPERIAL)	1
	K2-A074-M0	DIAL WITH 50 GRADUATIONS (METRIC)	1
75.	K2-A075-10	QUILL DIAL STOP NUT (IMPERIAL)	1
	K2-A075-M0	QUILL DIAL STOP NUT (METRIC)	1
76.	SE-16	SNAP RING	1
77.	SS-M4x16L	SOCKET SET SCREW	1
78.	K2-A078-00	TRIP LEVER PIN	1
79.	K2-A079-00	FEED TRIP LEVER	1
80.	K2-A080-00	FEED TRIP PLUNGER	1
81.	SC-M6x20L	SOCKET CAP SCREW	2
82.	K2-A082-00	GEARSHIFT PLUNGER	1
83.	SP-ø3x15L	SPRING PIN	1
84.	K2-A084-00	COMPRESSION SPRING	1
85.	K4-A085-00	FEED TRIP PLUNGER BUSHING	1
86.	SP-ø3x12L	SPRING PIN	1
87.	K4-A087-00	CAM ROD	1
89.	K2-A089-00	TRIP HANDLE	1
89-1.	BB-ø1/4"	BLACK PLASTIC BALL HANDLE	1
90.	K2-A090-00	TRIP HANDLE PIN	1
92.	K2-A092-00	FEED TRIP BRACKET	1
92-1.	K5-A092-00	WASHER	1
224.	K2-A224-00	HANDWHEEL HANDLE	1
225.	K2-A225-00	HANDWHEEL	1
226.	K2-A226-00	FEED REVERSE KNOB STUD	1
227.	K2-A227-00	REVERSE KNOB	1
228.	ES-5	SNAP RING	1
230.	KY-3x3x10L	KEY	1
231.	K6-A231-01	REVERSE CLUTCH ROD	1
232.	K6-A232-00	FEED WORM SHAFT	1
233.	K2-A233-00	HANDWHEEL CLUTCH	1
234.	SS-M6x6L	SOCKET SET SCREW	1
235.	K5-A235-00	FEED WORM SHAFT THRUST WASHER	1
236.	K2-A236-00	WORM SHAFT BUSHING	1
236-3.	S-22	SNAP RING	1
237.	K2-A237-00	WORM	1
239.	K2-A239-00	BUSHING	1
241.	K2-A241-00	FEED REVERSE BEVEL GEAR	2
242.	KY-3x3x15L	KEY	1
243.	SP-ø3x20L	PIN	1
244.	K2-A244-00	FEED REVERSE CLUTCH	1
267.	K2-A267-00	COMPRESSION SPRING	1
268.	SS-M8x6L	SOCKET SET SCREW	1
269.	BS-φ 3/16"	STEEL BALL	1
274.	K2-A274-00	PIN	1
275.	K2-A275-00	WASHER	2
276.	K2-A276-00	TRIP PLUNGER BUSHING	1

12.6 HEAD STOCK INFRASTRUCTURE (4) DRAWING

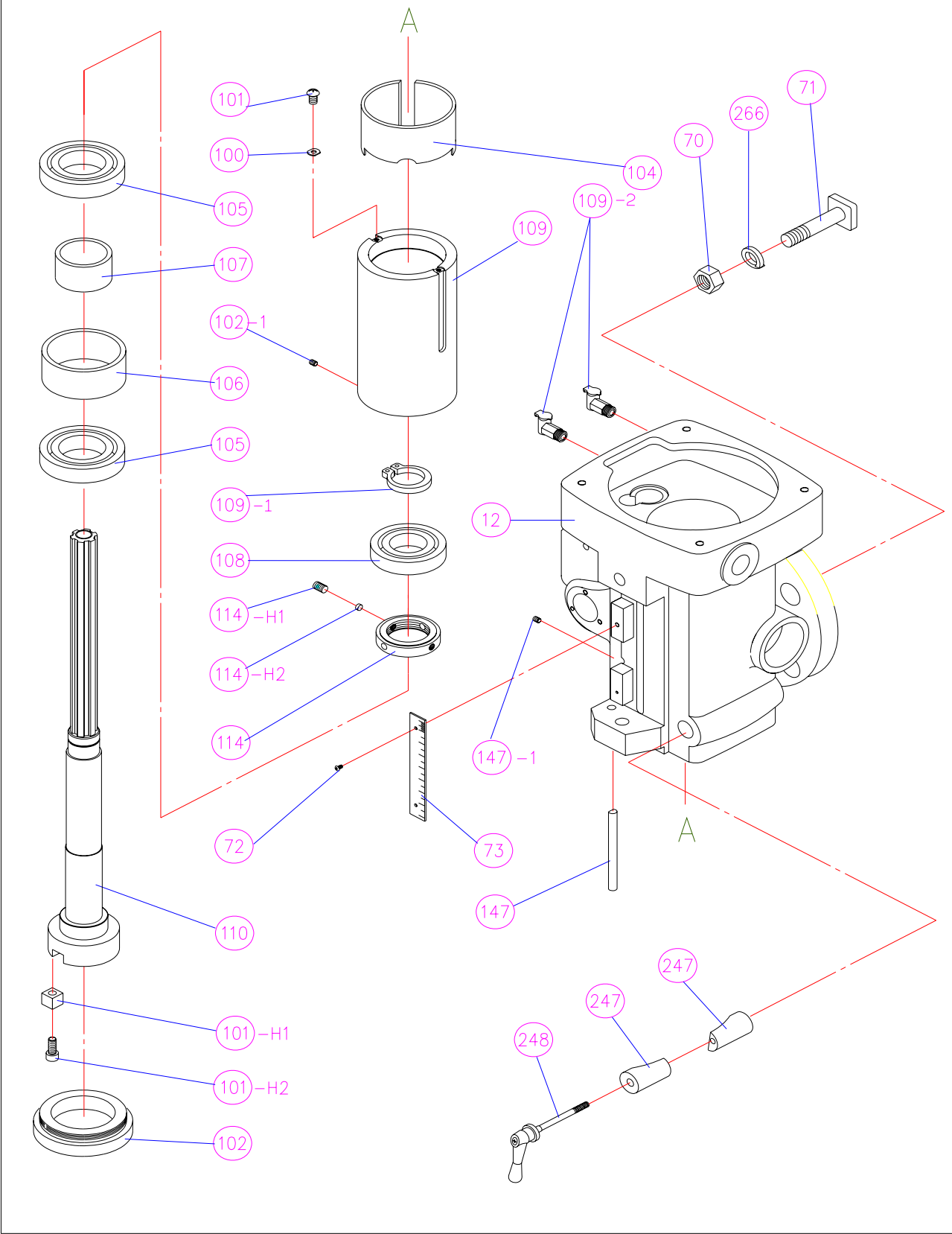

HEAD STOCK INFRASTRUCTURE (4) PARTS LIST

NO.	PART NO.	DESCRIPTION	QTY
12.	F4-A012-01	QUILL HOUSING	1
70.	K4-A070-00	HEX. NUT	4
71.	K5-A071-00	5/8"x65L T-BOLT	4
72.	SR-M3x4L	ROUND HEAD SCREW	2
73.	K5-A073-I0	MICROMETER SCALE (IMPERIAL)	1
	K5-A073-M0	MICROMETER SCALE (METRIC)	1
100.	K2-A100-00	WASHER	2
101.	SR-M5x8L	ROUND HEAD SCREW	2
101-H1.	K2-A110-A0	LOCK BLOCK	2
101-H2.	SC-5/16"x5/8"	SOCKET CAP SCREW	2
102.	K6-A102-00	#7207 NOSE-PIECE #40,R8	1
102-1.	SC-M5x6L	SET SCREW	1
104.	K6-A104-00	OIL BAFFLE	1
105.	7210B	BEARING	2
106.	K5-A106-00	BUSHING	1
107.	K5-A107-00	BUSHING	1
108.	6208	BEARING	1
109.	K6-A109-00	SLEEVE	1
109-1.	SE-40	SNAP RING	1
109-2.	OC-1/8" PT	OIL CAP	1
110.	K6-A110-00	SPINDLE	1
114.	K5-A114-00	LOCK NUT	1
114-H1.	SS-M8x8L	SET SCREW	1
114-H2.	K2-A185-00	PRESSURE WASHER	1
147.	K2-B147-00	STOP PIN	1
147-1.	SS-M6x8L	SOCKET SET SCREW	1
247.	K5-A247-00	QUILL LOCK SLEEVE	1
248.	K4-A248-00	QUILL LOCK BOLT	1
266.	K4-A266-00	WASHER	4

12.7 COLUMN, BASE ASSEMBLY DRAWING

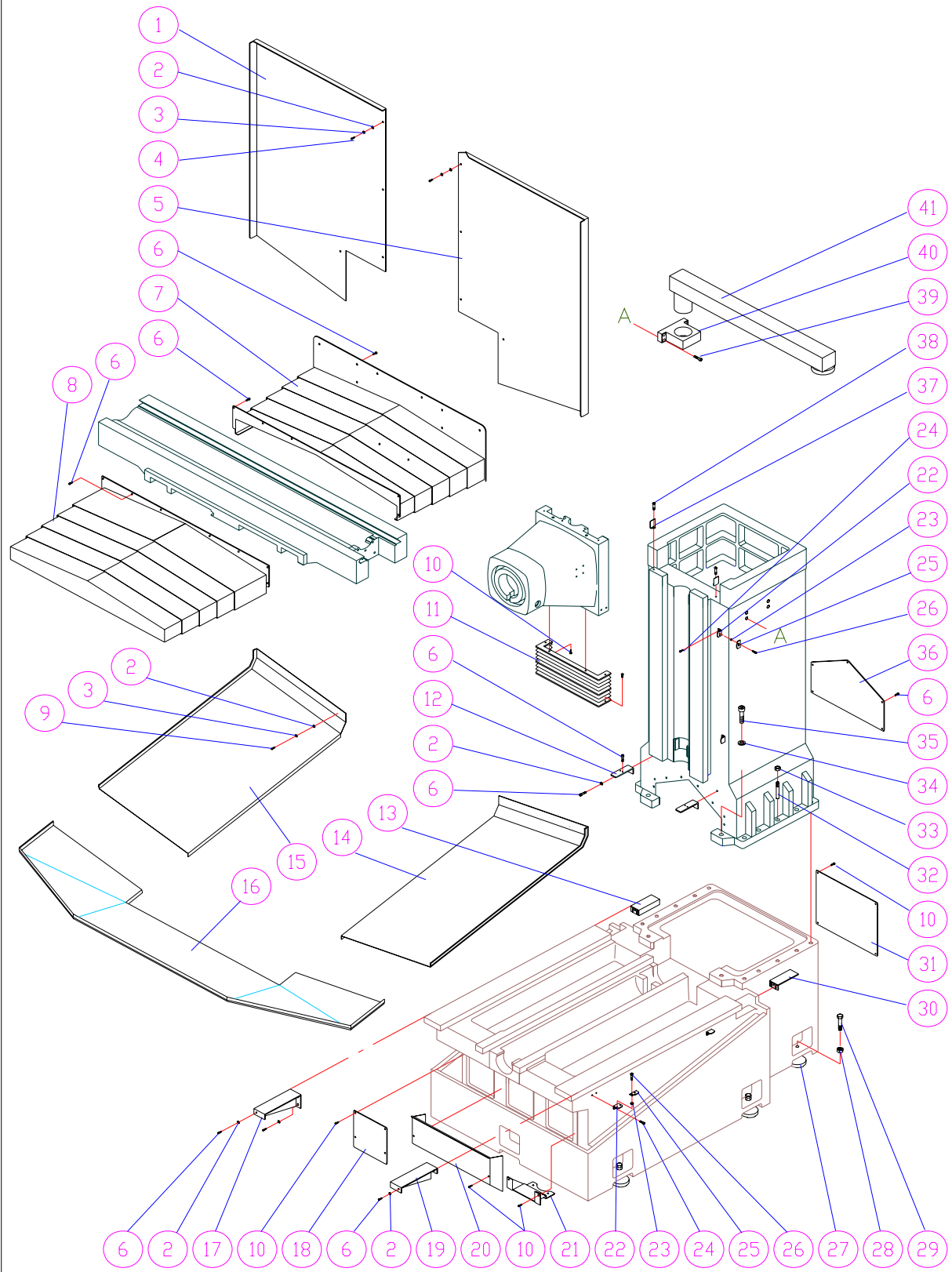

COLUMN, BASE ASSEMBLY PARTS LIST

NO.	PART NO.	DESCRIPTION	QTY
1.	B7-A115-L0	CHIP GUARD	1
2.	WF-ø6	FLAT WASHER	18
3.	WS-ø6	SPRING WASHER	8
4.	SB-M6x8L	HEX. SOCKET BUTTON HEAD SCREW	4
5.	B7-A115-R0	CHIP GUARD	1
6.	SC-M6x12L	SOCKET CAP SCREW	23
7.	B7-Y047-00	CHIP GUARD	1
8.	B7-Y045-00	CHIP GUARD	1
9.	SB-M6x12L	HEX. SOCKET BUTTON HEAD SCREW	4
10.	SR-M6x6L	ROUND HEAD SCREW	8
11.	B6-Z009-00	BOWL GUARD	1
12.	B6-Y042-00	BRACKET	2
13.	B7-Y048-L0	BRACKET	1
14.	B7-A120-R0	CHIP TRAY	1
15.	B7-A120-L0	CHIP TRAY	1
16.	B7-A120-F0	CHIP TRAY	1
17.	B7-Y046-L0	BRACKET	1
18.	B7-A007-01	COVER	1
19.	B7-Y046-R0	BRACKET	1
20.	B7-Y022-01	COVER	1
21.	B7-A010-01	COOLANT PUMP BASE	1
22.	B6-X016-A1	DOG	2
23.	HN-M6	NUT	8
24.	SC-M5x8L	SOCKET CAP SCREW	8
25.	B6-X019-01	DOG	2
26.	SC-M5x12L	SOCKET CAP SCREW	4
27.	K5-C099-00	CHOCK	6
28.	HN-3/4"	NUT	6
29.	SH-3/4" x3"	ADJUSTING BOLT	6
30.	B7-Y048-R0	BRACKET	1
31.	B7-A008-00	COVER	1
32.	DF-6004-00	TAPER PIN	2
33.	HN-M8	NUT	2
34.	WS-ø16	SPRING WASHER	12
35.	SC-M16x75L	SOCKET CAP SCREW	12
36.	B7-A013-00	COVER PLATE	1
37.	B6-Y029-A1	COVER	2
38.	SR-M5x10L	ROUND HEAD SCREW	6
39.	SC-M8x30L	SOCKET CAP SCREW	4
40.	B6-C141-A1	BRACKET	1
41.	B6-C144-00	BOOM	1

12.8 TABLE, SADDLE ASSEMBLY DRAWING

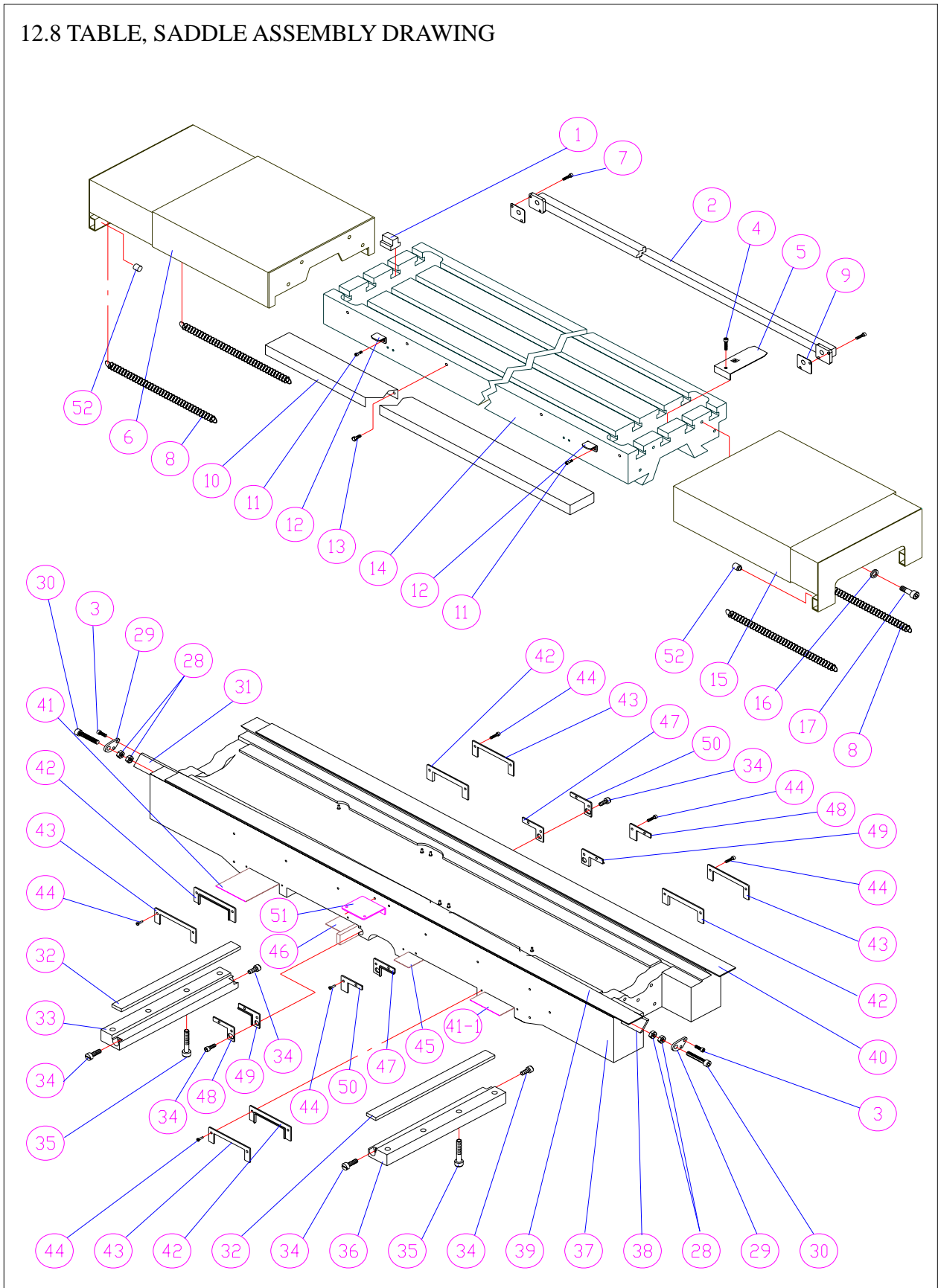

TABLE, SADDLE ASSEMBLY PARTS LIST

NO.	PART NO.	DESCRIPTION	QTY
1.	K2-D029-00	CHOCK PLUG	8
2.	B6-X060-00	DRAINAGE DEVICE	1
3.	SC-M6x20L	SOCKET CAP SCREW	4
4.	SC-M6x30L	SOCKET CAP SCREW	2
5.	B6-X040-00	STRAINER	2
6.	B7-X013-L0	BRACKET	1
7.	SR-M5x15L	POUND HEAD SCREW	4
8.	SG-ø8xø1x123L	SPRING	4
9.	B6-X063-00	PACKING	2
10.	B6-X020-01	LIMIT SWITCH COVER	1
11.	SC-M5x8L	SOCKET CAP SCREW	4
12.	B6-X016-01	DOG	2
13.	SC-M6x12L	SOCKET CAP SCREW	12
14.	B8-X001-00	WORK TABLE	1
15.	B7-X013-R0	BRACKET	1
16.	WS-ø8	SPRING WASHER	8
17.	SC-M8x25L	SOCKET CAP SCREW	8
28.	HN-M10	NUT	4
29.	B6-X047-00	WASHER	2
30.	SC-M10x60L	SOCKET CAP SCREW	2
31.	B7-X048-00	TABLE/SADDLE GIB (LEFT)	1
32.	B6-Z024-00	GIB	3
33.	B6-Z011-00	SLIDING PAIL	1
34.	K2-C041-00	GIB ADJ-SCREW	6
35.	SC-M12x45L	SOCKET CAP SCREW	8
36.	B6-Z010-00	SLIDING RAIL	1
37.	B8-X002-01	SADDLE	1
38.	B7-X049-00	TABLE/SADDLE GIB (RIGHT)	1
39.	B7-C136-00	TURCITE	1
40.	B7-C137-00	TURCITE	1
41.	B8-C138-L0	TURCITE	1
41-1.	B8-C138-R0	TURCITE	1
42.	B7-Y050-00	WIPER	4
43.	B7-Y051-02	WIPER HOLDER	4
44.	SC-M5x10L	SOCKET CAP SCREW	16
45.	B7-C132-00	TURCITE	1
46.	B7-C131-00	TURCITE	1
47.	B7-Y053-01	WIPER HOLDER	2
48.	B7-Y054-01	WIPER HOLDER	2
49.	B7-Y052-01	WIPER HOLDER	2
50.	B7-Y055-01	WIPER HOLDER	2
51.	B8-X015-00	X AXIS LIMIT SWITCH BASE	1
52.		SILENCER	4

12.10 X, Y ASSEMBLY DRAWING

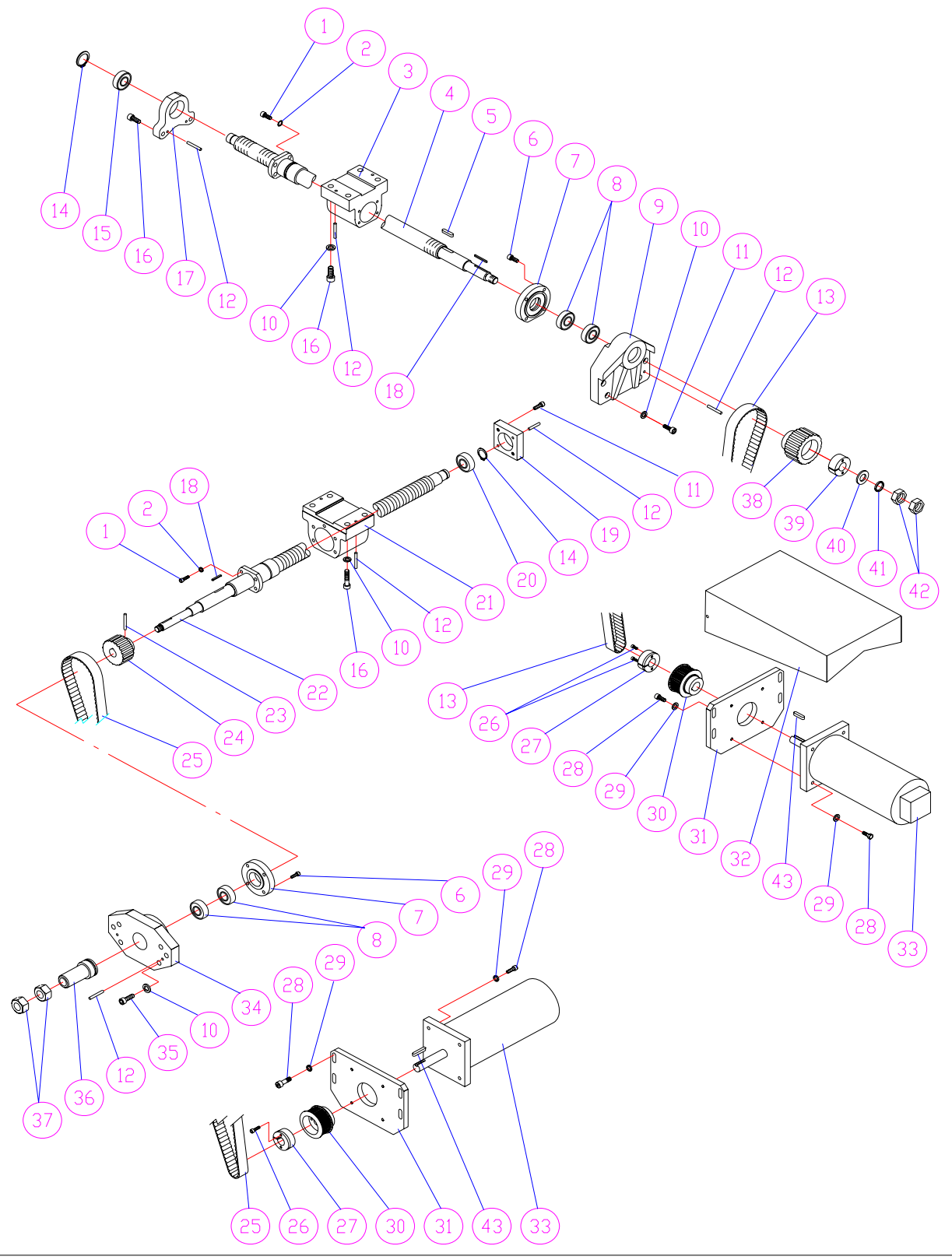

X,Y AXIS ASSEMBLY PARTS LIST

NO	PART NO	DESCRIPTION	QTY
1.	SC-M6x20L	SOCKET CAP SCREW	8
2.	WS-ø6	SPRING WASHER	8
3.	B6-Y080-00	Y AXIS FEED NUT BRACKET	1
4.	B6-X017-M1	X AXIS BALL SCREW	1
5.	KY-6x6x25L	KEY	1
6.	SC-M6x16L	SOCKET CAP SCREW	8
7.	B6-YA11-00	BEARING CAP	2
8.	25TAA06DB	BALL BEARING	4
9.	B6-X005-00	X AXIS BEARING BRACKET	1
10.	WS-ø10	SPRING WASHER	18
11.	SC-M10x35L	SOCKET CAP SCREW	6
12.	TP-#4x38L	TAPE PIN	11
13.	575-5Mx27	HTD BELT	1
14.	SE-20	SNAP RING	2
15.	6204ZZ	BALL BEARING	1
16.	SC-M10x40L	SOCKET CAP SCREW	10
17.	B7-X011-00	X AXIS BEARING BRACKET	1
18.	KY-6x6x25L	KEY	2
19.	B6-YA35-00	BEARING BRACKET	1
20.	6004ZZ	BALL BEARING	1
21.	B8-Y080-00	Y AXIS FEED NUT BRACKET	1
22.	B8-Y000-M2	Y AXIS BALL SCREW	1
23.	TP-#4x45L	TAPER PIN	1
24.	B6-Y030-T0	38T HTD GEAR	1
25.	615-5Mx27	HTD BELT	1
26.	SC-M6x30L	SOCKET CAP SCREW	4
27.	B3-X031-A1	LOCK BLOCK	2
28.	SC-M8x30L	SOCKET CAP SCREW	18
29.	WS-ø8	SPRING WASHER	16
30.	B6-X008-T1	38T HTD PULLEY	2
31.	B7-X025-00	X AXIS MOTOR BASE	2
32.	B7-X007-01	COVER	1
33.	SEM	SERVO MOTOR	2
34.	B6-YA07-00	Y AXIS BEARING BRACKET	1
35.	SC-M10x25L	SOCKET CAP SCREW	6
36.	B6-YA08-B0	SPACER	1
37.	HN-ø1/2"-20UNF	NUT	2
38.	B6-X030-T1	38T HTD GEAR	1
39.	B6-X031-02	LOCK BLOCK	1
40.	K5-C018-00	WASHER	1
41.	WS-ø16	SPRING WASHER	1
42.	HN-5/8"-18UNF	NUT	2
43.	KY-3/16"x25L	KEY	2

12.11 ELEVATING ASSEMBLY DRAWING

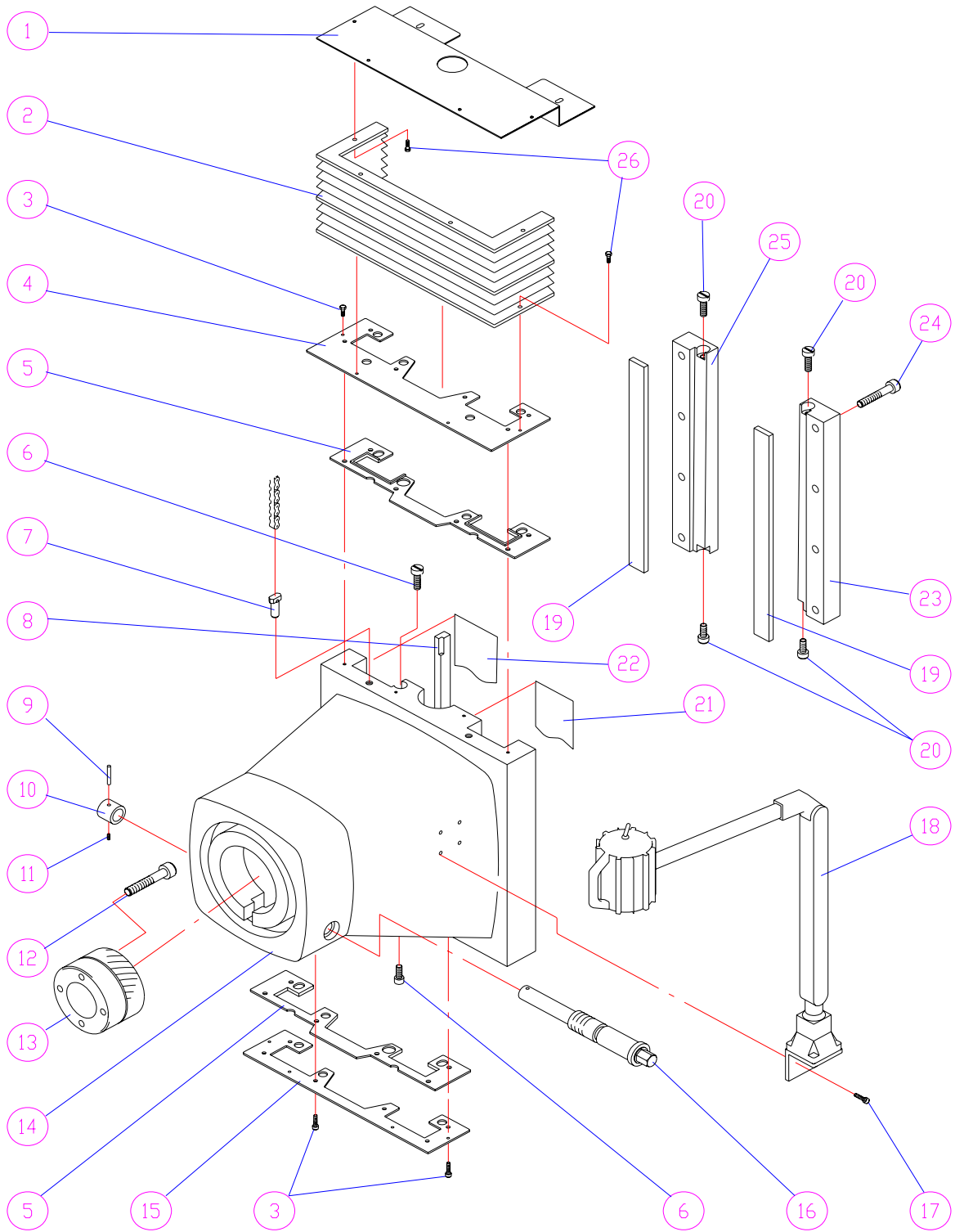

ELEVANTING ASSEMBLY PARTS LIST

NO	PART NO	DESCRIPTION	QTY
1.	B7-Z005-00	FIXED PLATE	1
2.	B6-Z006-00	RETRACTILITY COVER	1
3.	SR-M5x10L	ROUND HEAD SCREW	12
4.	B6-Z007-01	WIPER HOLDER	1
5.	B6-Z014-00	WIPER	2
6.	K2-C041-A0	GIB ADJ-SCREW	2
7.	B6-Z008-00	BALANCING SCREW	2
8.	B6-Z022-00	GIB	1
9.	SP-ø5x30L	SPRING PIN	1
10.	K5-C007-00	SPACER	1
11.	SS-M6x8L	SOCKET SET SCREW	1
12.	SC-M10x90L	SOCKET CAR SCREW	4
13.	K5-C001-00	QUILL HOUSING ADJ-GEAR	1
14.	B6-A002-00	ELEVANTING CASTING	1
15.	B6-Z013-01	WIPER HOLDER	2
16.	K5-C006-00	WORM SHAFT	1
17.	SC-M6x12L	SOCKET CAP SCREW	4
18.	WL-12V55W	WORK LAMP	1
19.	B6-Z024-00	GIB	2
20.	K2-C041-00	GIB ADJ-SCREW	4
21.	B6-Z021-00	TURCITE	1
22.	B6-Z020-00	TURCITE	1
23.	B6-Z010-00	SLIDING RAIL	1
24.	SC-M10x40L	SOCKET CAP SCREW	8
25.	B6-Z011-00	SLIDING RAIL	1
26.	SR-M6x6L	ROUND HEAD SCREW	8

12.12 Z AXIS ASSEMBLY DRAWING

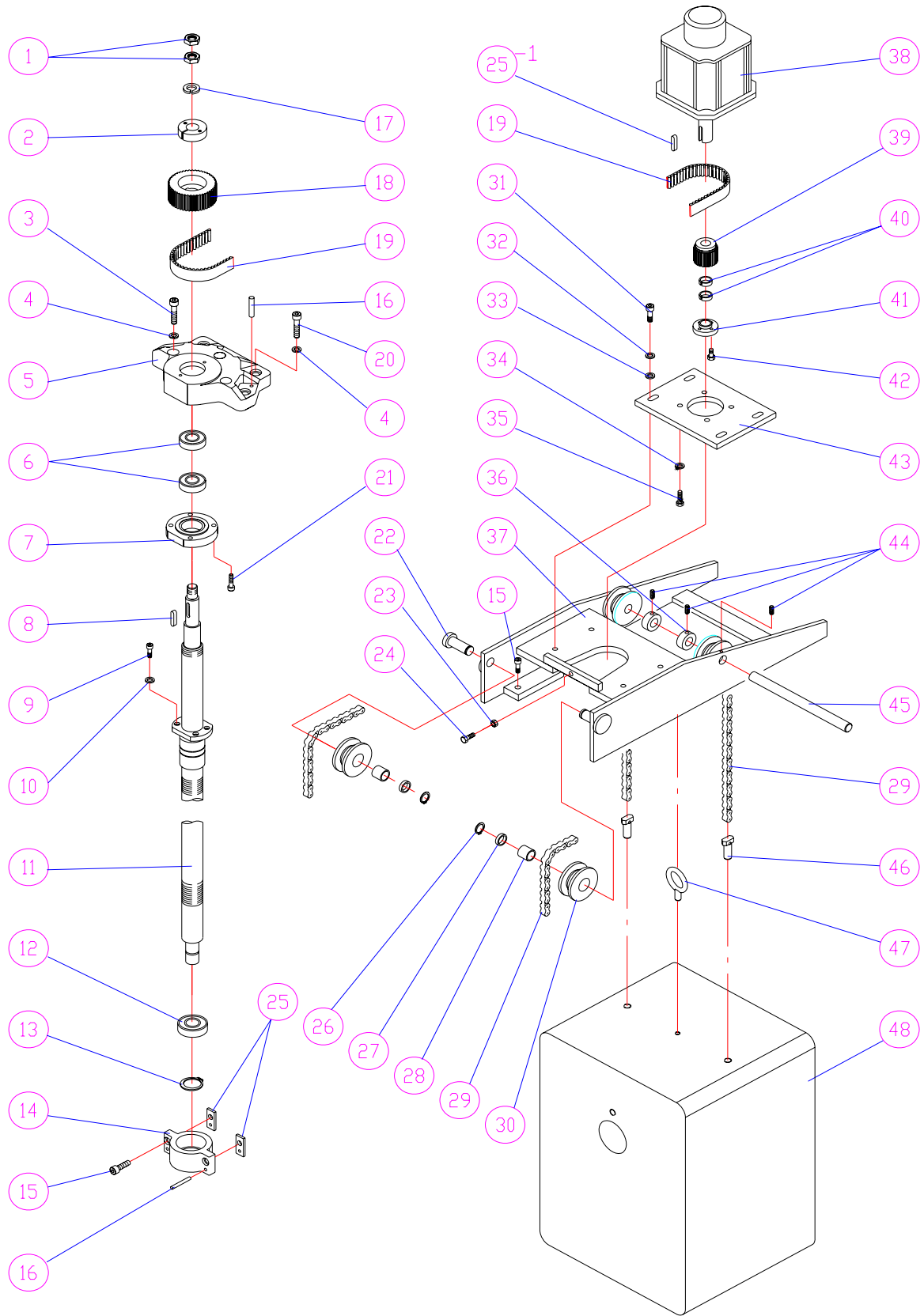

Z AXIS ASSEMBLY PARTS LIST

NO.	PART NO.	DESCRIPTION	QTY
1.	HN-5/8"-18UNF	NUT	2
2.	B6-X031-02	LOCK BLOCK	1
3.	SC-M10x50L	SOCKET CAP SCREW	3
4.	WS-ø10	SPRING WASHER	7
5.	B6-Z001-00	Z AXIS BALL BEARING BRACKET	1
6.	25TAA04DB	BALL BEARING	2
7.	B6-YA11-00	BEARING CAP	1
8.	KY-6x6x20L	KEY	1
9.	M6x20L	SOCKET CAP SCREW	4
10.	WS-ø6	SPRING WASHER	4
11.	B7-Z000-M0	Z AXIS BALL SCREW	1
12.	6204ZZ	BALL BEARING	1
13.	SE-20	SNAP RING	1
14.	B5-I011-01	BEARING BRACKET	1
15.	SC-M8x25L	SOCKET CAP SCREW	6
16.	TP-#4x38L	TAPER PIN	4
17.	WS-ø5/8"	SPRING WASHER	1
18.	B6-X030-01	48T HTD GEAR	1
19.	450-5Mx27	HTD BELT	1
20.	SC-M10x40L	SOCKET CAP SCREW	4
21.	SC-M5x20L	SOCKET CAP SCREW	6
22.	B6-Z036-01	SHAFT	2
23.	HN-M6	NUT	1
24.	SC-M6x25L	SOCKET CAP SCREW	1
25.	B6-Z004-00	CLAMPING PLATE	2
25-1.	KY-3/16"x25L	KEY	1
26.	SE-16	SNAP RING	2
27.	B6-Z039-00	SPACER	4
28.	BA-1012Z	BEARING	4
29.	RL-420-104L	CHAIN	2
30.	B6-Z037-00	BALANCING PULLEY	4
31.	SC-M8x20L	SOCKET CAP SCREW	8
32.	WS-ø8	SPRING WASHER	8
33.	WF-ø8	FLAT WASHER	4
34.	WS-ø6	SPRING WASHER	4
35.	SC-M6x25L	SOCKET CAP SCREW	4
36.	CF-6107-00	SPACER	2
37.	B6-Z029-00	BALANCING BASE	1
38.	MTS30U4-36	SERVO MOTOR	1
39.	B6-Z027-00	24T HTD GEAR	1
40.	SEC300	SEC300 LOCK RING (ø16xø20)	2
41.	B6-Z028-00	LOCK BLOCK	1
42.	SC-M4x16L	SOCKET CAP SCREW	4
43.	B6-Z034-00	MOTOR BASE	1
44.	SC-M6x8L	SOCKET CAP SCREW	3
45.	B6-Z038-00	BALANCING PULLEY SHAFT	1
46.	B6-Z008-00	BALANCING SCREW	2
47.	HB-M8	HOOK BOLT	1
48.	B6-A005-01	BALANCING BLOCK	1

12.13 LUBRICATION, COOLANT ASSEMBLY DRAWING

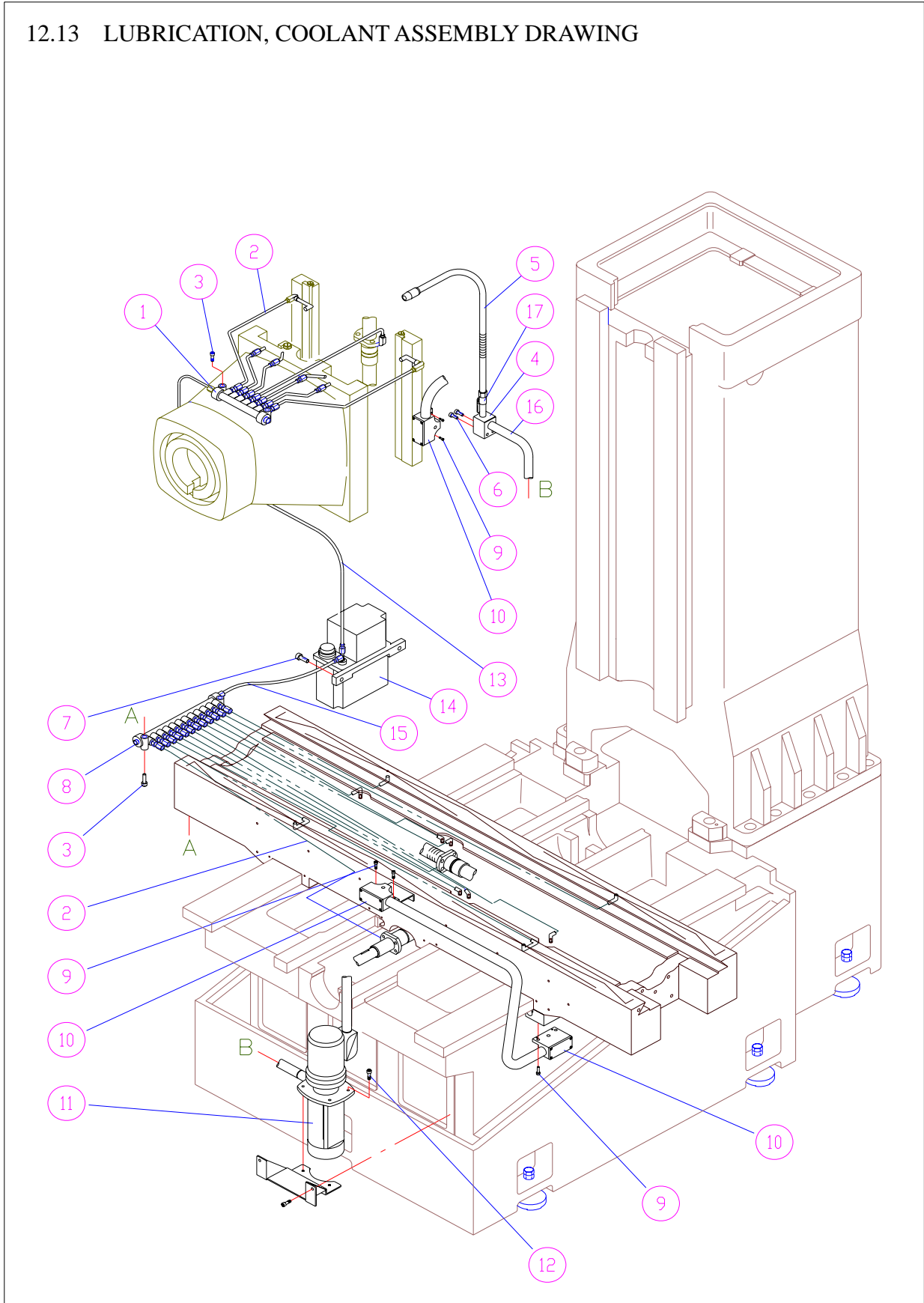

LUBRICATION, COOLANT ASSEMBLY PARTS LIST

NO.	PART NO.	DESCRIPTION	QTY
1.	OD-A7P	OIL DISTRUBTE	1
2.	LT-ø4	LUBRICATING OIL TUBING	19
3.	SC-M6x25L	SOCKET CAP SCREW	4
4.	B6-Z045-00	COOLANT TUBES BRACKET	1
5.	CT-3/8" x 36"	COOLANT TUBES	1
6.	SC-M6x40L	SOCKET CAP SCREW	2
7.	SC-M6x20L	SOCKET CAP SCREW	2
8.	OD-A12P	OIL DISTRIBUTE	1
9.	SC-M5x16L	SOCKET CAP SCREW	6
10.	LR50067	LIMIT SWITCH	3
11.	13L-1/8HP	COOLANT PUMP	1
12.	SC-M6x12L	SOCKET CAP SCREW	4
13.	LSø4x1.4M	LUBRICATING STRING	1
14.	CSED	ELECTRONIC LUBRICATION	1
15.	LSø4x1M	LUBRICATING STRING	1
16.	SCH-3/8" x 78"	STAINLESS STEEL COVEYING HOSES	1
17.	MFC-3/8"	MALE/FEMALE COCK	1