

Mechanical specification VTL30

Limit length : 99.7 in.  
 Limit width : 62.5 in.  
 Limit height : 101.4 in.  
 X-axis stroke : 20 in.  
 Z-axis stroke : 18 in.

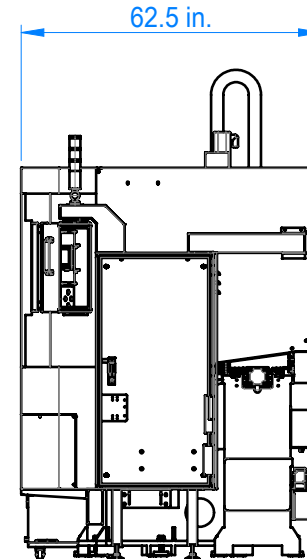
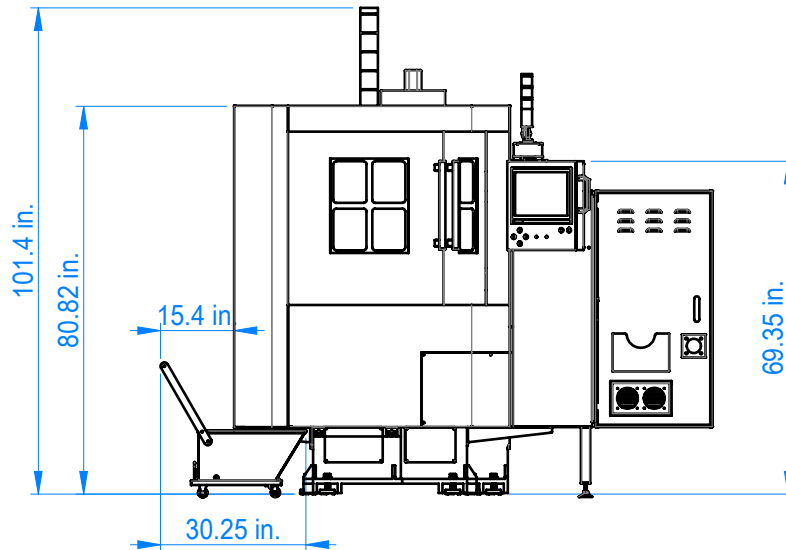
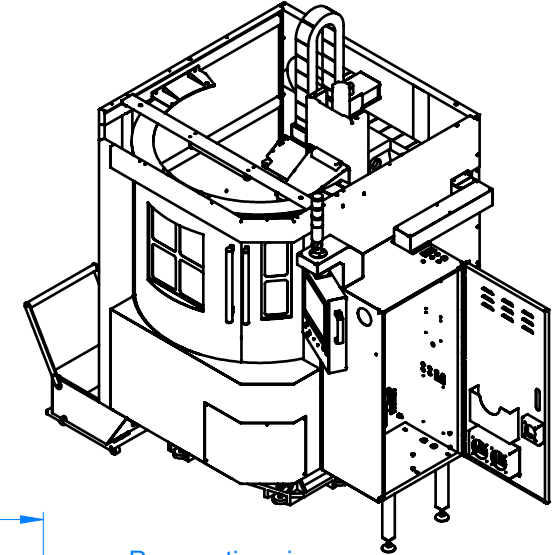
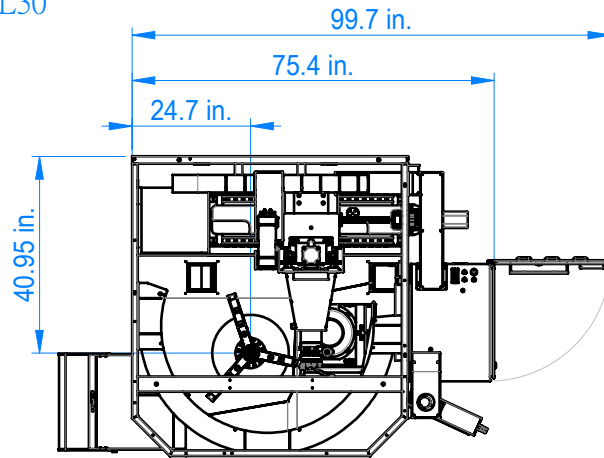

Estimated weight: 5000 lbs

5				Normal tolerance		Checker		Date	Surface treatment		Model	VTL30
4				Size range	Allowable tolerance	Design		Date	Material		Drawing name	Machinery Outline Scheme Diagram
3				1 - 6	±0.05	Drafter		Date	Quantity	1	Drawing No.	6033018003-1
2				6 - 30	±0.1	旭正機械股份有限公司 TOP-ONE MACHINERY CO.,LTD.			Scale	1:40		
1				30 - 100	±0.2				Projection	⊕	Version	1
No.	Content of changes	Revised by	Date	100 - 300	±0.3							
				300 - 2000	±0.5							