

M40 3 phase 220v to 440v

1. Move wire T2 at transformer from 220v to 440v

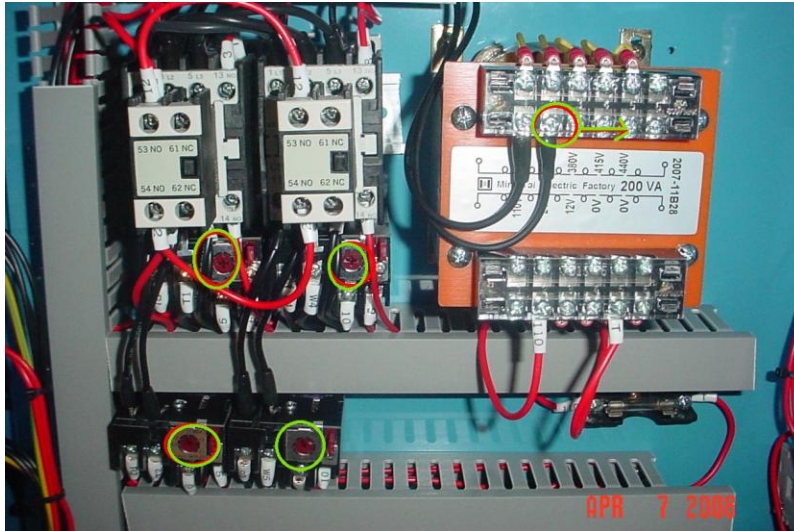

2. Change wires input to Spindle motor from 220v to 440v.

Open electric cover motor, behind the cover, they have instruction changed to 440v



3. Adjust over relay (amp) depend on motor.